

| Basic Specification   |  |
|---|--|
| Model   | YF35E3G-Q100<br>(Including Extended Model) |
| Type  | Low Side Shell Design<br>Scroll Compressor |
| Application   | Refrigeration                              |
| Power   | 5 HP                                       |
| Capacity (BTU/Hr)   | 14164                                      |
| Refrigerant   | R448A/R449A                                |
| Displacement(cc/rev)  | 83.3                                       |
| Cooling Capacity(W) <sup>(a)</sup>                          | 4150                                       |
| Input Power(W) <sup>(a)</sup>                               | 3360                                       |
| RLA(A) <sup>(a)</sup>                                       | 15.6                                       |
| Cooling COP(W/W) <sup>(a)</sup>                             | 1.24                                       |
| Power Supply  | 208-230V/1~/60Hz                           |
| Min. Operating Voltage(V)                                   | 187  |
| Max. Operating Voltage(V)                                   | 253  |
| LRA(A)  | 140  |
| Max. Operating Current(A) <sup>(b)</sup>                    | 33.5                                       |
| Rated Speed(r/min) <sup>(a)</sup>                           | 3500                                       |
| Compressor Weight (With Oil)(kg)                            | 38   |
| Oil Type  | POE  |
| Oil Kinematic Viscosity(cSt, 40°C)                          | 32   |
| Oil Density(kg/L, 20°C)                                     | 0.977                                      |
| Primary Charge(L)   | 1.6  |
| Recharge(L)   | 1.45                                       |
| Oil Circulation Rate <sup>(a)</sup>                         | ≤1%  |
| Rated Sound(Sound Power)(dBA) <sup>(c)</sup>                | 75   |
| Max. Operating Sound in Running Envelope (Sound Power)(dBA) | 80   |
| Vibration Displacement Peak-Peak(mm) <sup>(d)</sup>         | ≤0.1                                       |
| Moisture(mg)  | ≤500                                       |
| Impurity(mg)  | ≤100                                       |
| LVS(V) <sup>(e)</sup>                                       | 177  |
| MOV (V) <sup>(f)</sup>                                      | 187  |
| Start Capacitor(μF/V)                                       | 250  |
| Start Relay   | HLR3800-3F3C                               |
| Run Capacitor(μF/V)   | 100/450                                    |
| IP Class of Terminal Box                                    | IP21                                       |
| Compressor Color  | Black                                      |

| Motor Parameters                        |  |
|---|--|
| Motor Type                              | Single-phase asynchronous motor          |
| Motor Pole                              | 2  |
| Motor Insulation Class(°C)              | 130(B Class)                             |
| Line to Line Resistance UV(CS)(Ω, 25°C) | 0.777(±10%)                              |
| Line to Line Resistance UW(CR)(Ω, 25°C) | 0.395(±10%)                              |
| Line to Line Resistance VW(SR)(Ω, 25°C) | 1.172(±10%)                              |
| Dielectric Strength                     | 2000VAC / 1s / 60Hz, Leakage Current≤5mA |
| Insulation Resistance(MΩ)               | ≥20                                      |
| Ground Resistance(Ω)                    | ≤0.1                                     |

| Safety Operating Limit             |   |
|------------------------------------|---|
| Tightness Test Pressure (MPa)      | 3.8-4.0   |
| Max. Operating Pressure            |   |
| High Side(MPa)<br>Low Side(MPa)    | H3.2/L2.0   |
| Compressor FreeSpace (Without Oil) |   |
| High Side(L)<br>Low Side(L)        | H1.0/L3.7   |
| Max. Refrigerant Charge(kg)        | See Notes   |
| Discharge Temperature Limit(°C)    | ≤120<br>(120mm to compressor discharge connection and well insulated) |
| Start-Stop Interval                | See Notes   |

Performance Condition:

| Condition | Condition Description   |
|-----------|---|
| a         | Rated Condition   |
| b         | Max. Load Condition, 90% Rated Voltage  |
| c         | Rated Condition, A Weighted Sound Power   |
| d         | Rated Condition, Max Operating Normal Displacement of Compressor Housing        |
| e         | Discharge Pressure and Suction Pressure: Saturated Refrigerant Pressure at 40°C |
| f         | Max. Load Condition   |

2. Rated Condition, 48 Hours Break-in-Running before implementing Performance and Sound Testing

| Item   | Rated Condition    | Max. Load Condition |
|--|--------------------|---------------------|
| E.T.(°C)/C.T.(°C)/S.H.(K)/<br>S.C.(K)/A.T.(°C) | -31.6/40.6/36/0/35 | 0/60/20/0/46.1      |
| Cooling Capacity Deviation                     | ≥90.0%             | -                   |
| Power Deviation                                | ≤110.0%            | -                   |
| COP Deviation                                  | ≥90.0%             | -                   |

3. Internal Protector

| Protection Method               | Config  | Parameter        |               |          |
|---------------------------------|---------|------------------|---------------|----------|
| Internal Overload Protector     | With    | Vendor           | Vendor 1      | Vendor 2 |
|                                 |         | Model            | UP16QC051A-XX |          |
|                                 |         | Open Temp.(°C)   | 150±5         |          |
|                                 |         | Close Temp. (°C) | 80±9          |          |
|                                 |         | Short Time Trip  | 155A<br>3-10s | A<br>S   |
| Internal Pressure Relieve Valve | Without | -MPa             |               |          |

4. Accessory

| Item | Name     | P.N.        | PCS |
|------|----------|-------------|-----|
| 1    | Grommet  | 070-0003-00 | 4   |
| 2    | Sleeve   | 010-0014-00 | 4   |
| 3    | StartBox | 110-0076-10 | 1   |
| 4    | TREV     | 100-0002-01 | 1   |

5. Compressor Operating Envelope

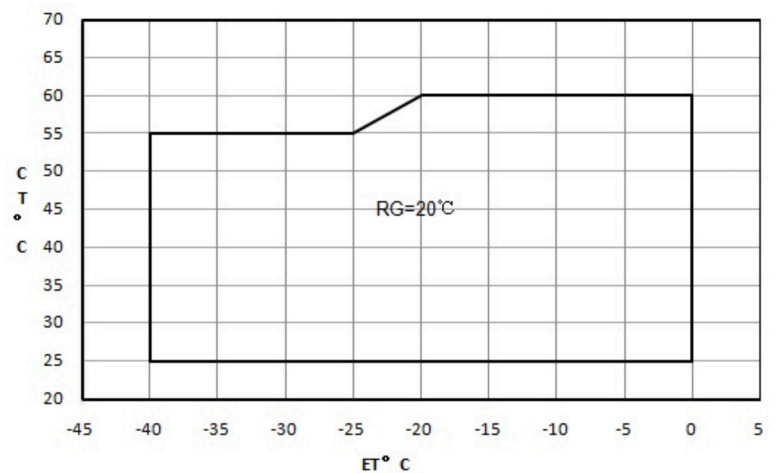

Compressor Performance Sheet

- » Performance Based on Superheat is within the Operating Envelope, Subcooling after Condenser is OK;
- » Performance Calculated by Coefficients of Polynomial is Only Suitable for the Condition within Operating Envelope
- » Capacity, Power can be Calculated by Coefficients of Polynomial

Performance Table

| Item             | E.T. (°C)<br>C.T. (°C) | Temperature (°C) |      |      |      |      |       |       |       |       |
|------------------|------------------------|------------------|------|------|------|------|-------|-------|-------|-------|
|                  |                        | -40              | -35  | -30  | -25  | -20  | -15   | -10   | -5    | 0     |
| Cooling Cap. (W) | 60                     |                  |      |      |      | 5452 | 6686  | 8178  | 9960  | 12064 |
|                  | 55                     | 2623             | 3211 | 3930 | 4814 | 5895 | 7206  | 8780  | 10650 | 12848 |
|                  | 50                     | 2780             | 3430 | 4216 | 5173 | 6332 | 7727  | 9389  | 11353 | 13650 |
|                  | 45                     | 2902             | 3620 | 4481 | 5517 | 6761 | 8245  | 10003 | 12067 | 14470 |
|                  | 40                     | 2988             | 3782 | 4723 | 5844 | 7179 | 8760  | 10619 | 12790 | 15306 |
|                  | 35                     | 3037             | 3912 | 4939 | 6153 | 7585 | 9269  | 11236 | 13521 | 16155 |
|                  | 30                     | 3045             | 4008 | 5129 | 6441 | 7977 | 9770  | 11852 | 14257 | 17016 |
| Power (W)        | 25                     | 3012             | 4069 | 5290 | 6707 | 8353 | 10262 | 12465 | 14996 | 17887 |
|                  | 60                     |                  |      |      |      | 5665 | 5881  | 6106  | 6337  | 6568  |
|                  | 55                     | 4360             | 4492 | 4651 | 4833 | 5033 | 5246  | 5465  | 5688  | 5908  |
|                  | 50                     | 3838             | 3975 | 4138 | 4320 | 4517 | 4723  | 4935  | 5146  | 5352  |
|                  | 45                     | 3422             | 3562 | 3724 | 3904 | 4095 | 4294  | 4494  | 4692  | 4881  |
|                  | 40                     | 3091             | 3231 | 3391 | 3566 | 3749 | 3937  | 4124  | 4305  | 4475  |
|                  | 35                     | 2825             | 2963 | 3118 | 3284 | 3457 | 3632  | 3802  | 3965  | 4113  |
|                  | 30                     | 2604             | 2737 | 2884 | 3040 | 3200 | 3358  | 3510  | 3651  | 3775  |
|                  | 25                     | 2407             | 2533 | 2670 | 2813 | 2956 | 3096  | 3227  | 3343  | 3441  |

Ten Coefficients of Polynomial

| Expression          | $z = p_0 + p_1x + p_2y + p_3x^2 + p_4x^2y + p_5y^2 + p_6x^3 + p_7x^2y + p_8x^2y^2 + p_9y^3$  |              |             |
|---------------------|--|--------------|-------------|
| Description         | z: Cooling Capacity(W) or Power (W)<br>Specially: Heating Capacity(W)=Cooling Capacity(W)+Power (W)<br>x: E.T. °C<br>y: C.T. °C<br>p0~p9: Coefficients of Polynomial |              |             |
| Cooling Cap. Factor | Value  | Power Factor | Value       |
| p0                  | 22325.0393   | p0           | 1110.182112 |
| p1                  | 770.259156   | p1           | -18.925488  |
| p2                  | -178.380576  | p2           | 135.466428  |
| p3                  | 8.397456   | p3           | -0.761472   |
| p4                  | -6.797688  | p4           | 1.705824    |
| p5                  | -0.02838   | p5           | -2.367372   |
| p6                  | 0.043716   | p6           | -0.006708   |
| p7                  | -0.02136   | p7           | 0.0111      |
| p8                  | 0.025848   | p8           | -0.010416   |
| p9                  | 0.00252  | p9           | 0.027096    |

Notes: Coefficients of polynomial are based on the fitting results of some sample data, which can be used as a reference of compressor selection, but cannot completely eliminate customer's test.

Drawings  
Outline Drawing

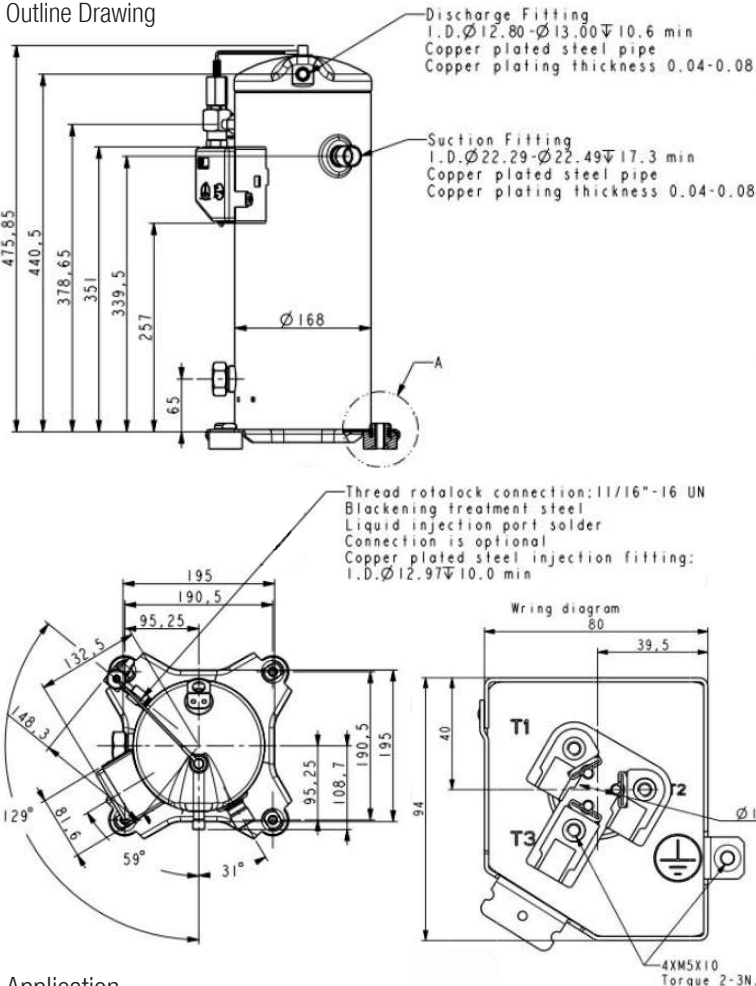

Application

- » See Details in the YF serial LBP refrigerant scroll compressor application manual

Notes

- » It is not allowed to perform vacuum in the system by using the refrigeration compressor. The compressor can start only after the refrigerant charged. In some cases, such as on the field site, if it is limited by the situation that can't charge the required volume of refrigerant, 50% of the required refrigerant is charged necessary before the compressor starts. Double check the system and make sure everything is under safe status, then power on the compressor and charge the remained refrigerant when the compressor is running.
- » It is not allowed to charge the refrigerant from the suction or discharge line closes to the compressor. The charge port should be arranged on the connection pipe of suction line accumulator or receiver, which is on the side far away to the compressor, to avoid the liquid refrigerant flood back.
- » Refrigerant charge limitation: the ratio between the weight of oil and refrigerant should be  $\geq 0.4$ .
- » It is not allowed to vacuum by compressor, not allowed to run the compressor without refrigerant, and not allowed to run the compressor on the reversed direction for long duration.
- » The compressor can only work with approved refrigerant.
- » The compressor is not allowed to work outside its envelope, the system should guarantee the suction line superheat and avoid the liquid refrigerant flood back.
- » When the suction and discharge plugs are removed, the assembly and brazing should be done in 15 minutes.
- » The frequently start/stop should be avoided. The suggested minimum continuous running time is 10 minutes to guarantee the safe oil level ( $\geq 50\%$  initial charge volume), the suggested minimum interval duration between start and stop is 3 minutes.
- » The deviation of supplied voltage should be less than  $\pm 10\%$  of rated voltage.
- » A 70W crankcase heater is recommended to avoid the refrigerant migration during the off circle and flood start. The crankcase heater should be power on 12 hours earlier than the first start or restart after long duration off.
- » The system should be equipped with necessary protection devices, such as pressure, temperature, oil return, overcurrent and phase fault, etc.
- » The compressor is not allowed to lay down or place upside down during transportation, stock and installation. The maximum inclination is  $15^\circ$  when the compressor is running.

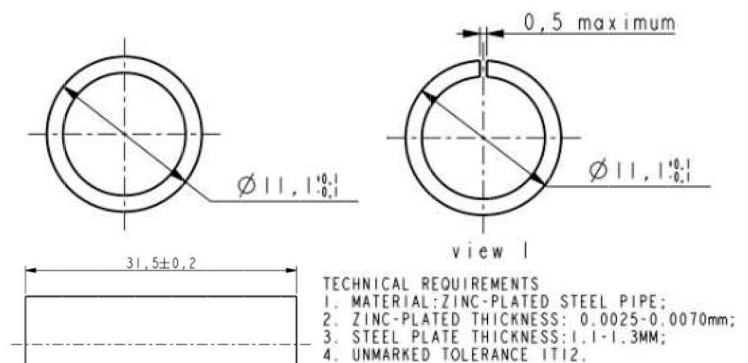
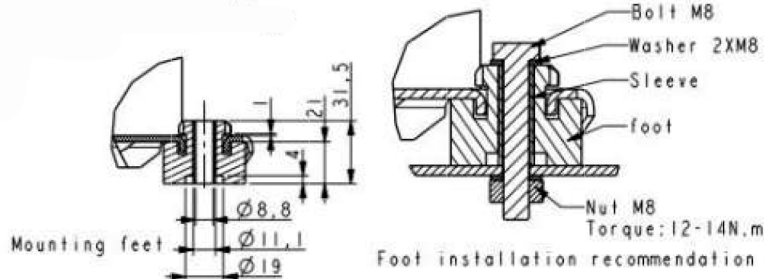

Grommet Drawing

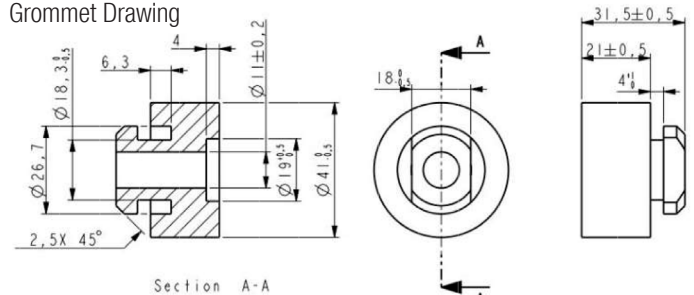

Single Phase Compressor Wiring Diagram

