



YORK[®]

ROOFTOP

User's Manual

New Released

Form: IMMRZCTAJ-200815

ROOFTOP PACKAGE AIR CONDITIONERS R410A (60HZ)



YMMRZC020TAQ-B-X

YMMRZC020TAJ-B-X

YMMRZC025TAQ-B-X

YMMRZC025TAJ-B-X

Issue Date
Aug 5, 2020





ACCESSORIES.....	1
GENERAL INFORMATION.....	1
UNIT DIMENSIONS.....	3
LOCATIONS AND RECOMMENDATIONS.....	4
INSTALLATION.....	4
ELECTRICAL WIRING.....	6
SPECIFICATION.....	10
START-UP	15
MAINTENANCE.....	15

■ **Nomenclature**

CODE	NAME
C/O	Cooling Only
E/Heater+C	Cooling units with Electric Heater
Hor.	Horizontal Units

1. ACCESSORIES

Tab.1-1

Name of accessories	Qty	Shape
Manual	1	
Drain outlet	1	
Snap ring	1	
Drain pipe	1	
Wire controller	1	

2. GENERAL INFORMATION

Warnings and Cautions appear at appropriate locations throughout this manual.

Read these carefully.



WARNING: Indicates a potentially hazardous situation which, if not avoided, could result in death or serious injury.



CAUTION: Indicates a potentially hazardous situation which, if not avoided, may result in minor or moderate injury. It may also be used to alarm against unsafe practices and where property-damage-only accidents could occur.



CAUTION

- Read this entire manual before beginning installation procedures.
- Bodily injury can result from high voltage electrical components, fast moving fans. For protection from these inherent hazards during installation and servicing, the electrical supply must be disconnected.
- If operating checks must be performed with the unit operating, it is the technicians responsibility to recognize these hazards and proceed safely.



WARNING

- **Ask your dealer for installation of the air conditioner.**
Incomplete installation performed by yourself may result in a water leakage, electric shock, and fire.
- **Ask your dealer for improvement, repair, and maintenance.**
Incomplete improvement, repair, and maintenance may result in a water leakage, electric shock, and fire.
- **In order to avoid electric shock, fire or injury, or if you detect any abnormality such as smell of fire, turn off the power supply and call your dealer for instructions.**
- **Never replace a fuse with that of wrong rated current or other wires when a fuse blows out.**
Use of wire or copper wire may cause the unit to break down or cause a fire.
- **Do not insert fingers, rods or other objects into the air inlet or outlet.**
When the fan is rotating at high speed, it will cause injury.
- **Never use a flammable spray such as hair spray, lacquer or paint near the unit.** It may cause a fire.
- **Never inspect or service the unit by yourself.**
Ask a qualified service person to perform this work.
- **Keep far away from high-frequency equipment.**
- **Keep away from the following places:**
A place where it is full of oil, gas; places where salty air surrounding(near the coast); and a place where is caustic gas(the sulfide in hot spring). Location in above places may cause malfunction or shorten the life span of the machine.
- **In the case of extremely strong wind, please prevent the air from flowing backwards into the outdoor unit.**
- **Snow canopy is necessary in snowfall places on the outdoor unit. Please consult the local dealer for details.**
- **In the frequent thunderstruck place, lightning proof actions should be taken.**
- **To prevent refrigerant leak, contact your dealer.**
When the system is installed and runs in a small room, it is required to keep the concentration of the refrigerant, if by any chance coming out, below the limit. Otherwise, oxygen in the room may be affected, resulting in a serious accident.
- **The refrigerant in the air conditioner is safe and normally does not leak.**
If the refrigerant leaks in the room, contact with a fire of a burner, a heater or a cooker may result in a harmful gas.
- **Turn off any combustible heating devices, ventilate the room, and contact the dealer where you purchased the unit.**
Do not use the air conditioner until a service person confirms that the portion where the refrigerant leaks is repaired.
- **If the supply cord is damaged, it must be replaced by the manufacturer or its service agent or a similarly qualified person in order to avoid a hazard.**
- **The temperature of refrigerant circuit will be high, please keep the interconnection cable away from the copper tube.**
- **The appliance should not be used by children without supervision.**



WARNING

- Check the electric wire, water and gas pipeline layout inside the wall, floor and ceiling before installation. Do not implement drilling unless confirm safety with the user, especially for the hidden power wire. An electroprobe can be used to test whether a wire is passing by at the drilling location, to prevent physical injury or death caused by insulation broken cords.
- Check the power supply before installation. Ensure that the power supply must be reliably grounded following local, state and National Electrical Codes. If not, for example, if the ground wire is detected charged, installation is prohibited before it is rectified. Otherwise, there is a risk of fire and electric shock, causing physical injury or death.



CAUTION

Do not dry out the air filter under direct sunshine or heat.

- Re-install the air filter
- Condenser coil
Unfiltered air circulates through the unit's condenser coil can cause the coil's surface to become clogged with dust, etc. Clean the coil, vertically (i.e., with the fins), and stroke the coil surface with a soft brush. Be sure to keep all vegetation away from the condenser coil area.
- Maintenance performed by serviceman.
To keep your unit operating safely and efficiently, the manufacturer recommends that a qualified serviceman check the entire system at least once each year and any other time that you feel one is needed. Your serviceman should examine these areas of your unit:
 - Filters
 - Motors and drive system components
 - Economizer gaskets (for possible replacement)
 - Safety controls (for mechanical cleaning)
 - Electrical components and wiring (for possible replacement and connection tightness)
 - Condensate drain (for cleaning)
 - Unit duct connections (to see that they are physically sound and sealed to the unit casing)
 - Unit mounting support (for structural integrity)
 - The unit (for obvious unit deterioration)



CAUTION

- Do not operate the unit without the evaporator fan access panel in place. Reinstall the access panel after performing any maintenance. Operating the unit without the access panel may result in severe personal injury or death.
- This unit is not intended for use by persons (including children) with reduced physical, sensory or mental capabilities, or lack of experience and knowledge, unless they have been given supervision or instruction concerning use of the appliance by a person responsible for their safety. Children should be supervised to ensure that they do not play with the unit.
- Disconnect the power supply before cleaning and maintenance.
- The unit shall be installed in accordance with national wiring regulations.



DISPOSAL: Do not dispose this product as unsorted municipal waste. Collection of such waste separately for special treatment is necessary.

- Do not dispose of electrical appliances as unsorted municipal waste, use separate collection facilities.
- Contact your local government for information regarding the collection systems available.
- If electrical appliances are disposed of in landfills or dumps, hazardous substances can leak into the groundwater and get into the food chain, damaging your health and well-being.

3. UNIT DIMENSIONS

- YMMRZC020TAQ-B-X & YMMRZC020TAJ-B-X
YMMRZC025TAQ-B-X & YMMRZC025TAJ-B-X

Units: mm

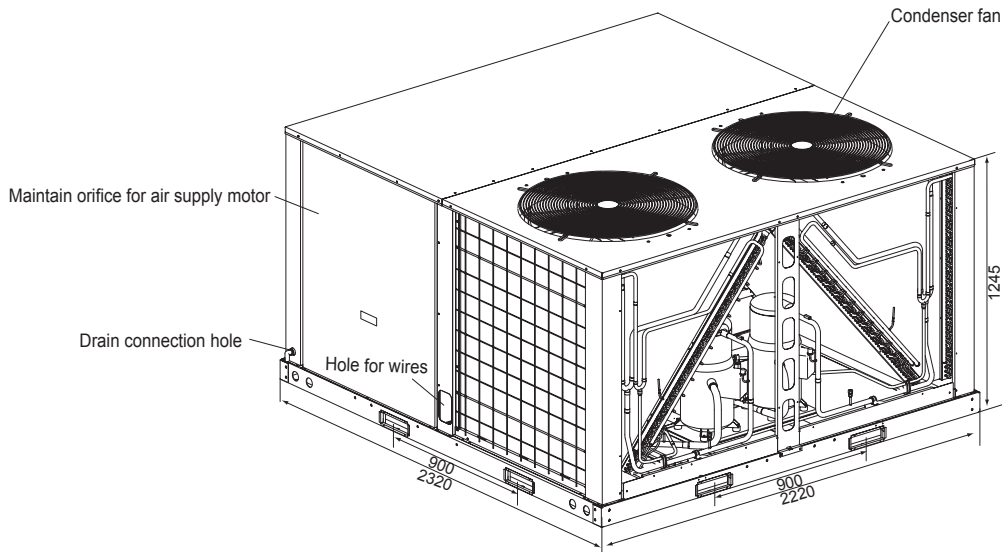

Fig.3-4

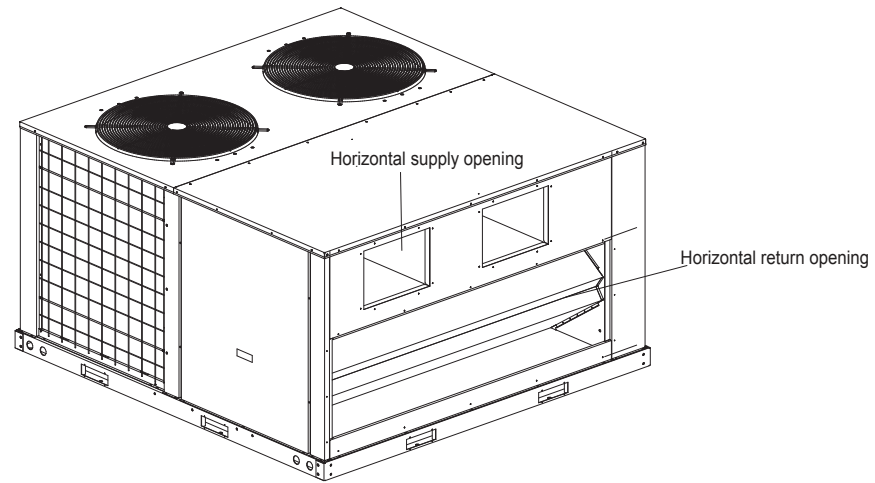

Fig.3-5

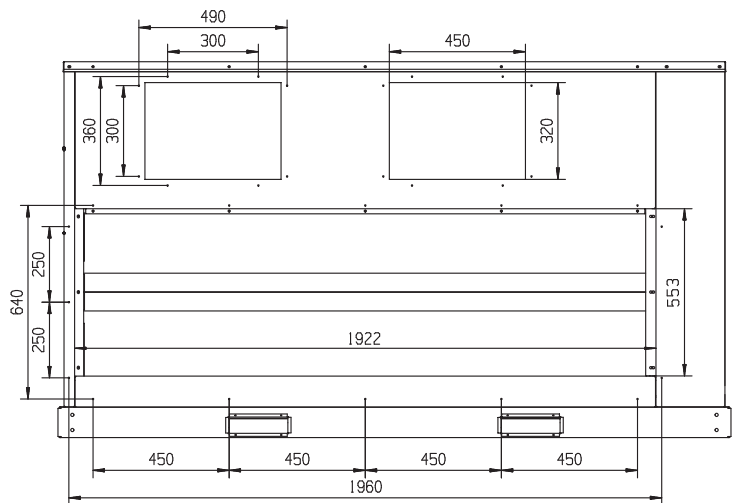
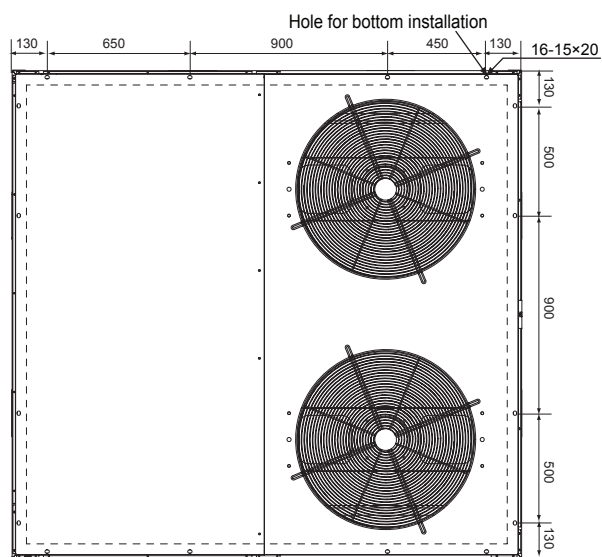

Fig.3-6

4. LOCATIONS AND RECOMMENDATIONS

4.1 Horizontal airflow application

- These units are designed and certified for outdoor installations. These units may be installed directly on wood flooring or on Class A, Class B, or Class C roof covering material.
- Location of the unit must allow service clearance around it. Clearance of the unit must be given careful consideration.
- Check the handling facilities to ensure the safety of personnel and the unit(s).
- Caution must be taken at all times to avoid Personal injuries and/or damage to equipment.
- The unit must be mounted level for proper drainage of water through the holes in the base pan.
- The unit must not be exposed to direct roof water runoff.
- Flexible duct connectors must be of a flame retardant material. All duct work outside of the structure must be insulated and weatherproofed in accordance with local codes.
- Holes through exterior walls must be sealed in accordance with local codes.
- All fabricated outdoor ducts should be as short as possible.

4.2 Clearances

- The recommended clearances for single-unit installations are illustrated in Fig.4-1. These minimum requirements are not only an important consideration when determining unit placement, but they are also essential to ensure adequate serviceability, maximum capacity, and peak operating efficiency.
- Any reduction of the unit clearances indicated in these illustrations may result in condenser coil starvation or the recirculation of warm condenser air. Actual clearances which appear to be inadequate should be reviewed with a local engineer.
- See the unit's nameplate for the absolute minimum clearance between the unit and any combustible surface(s).

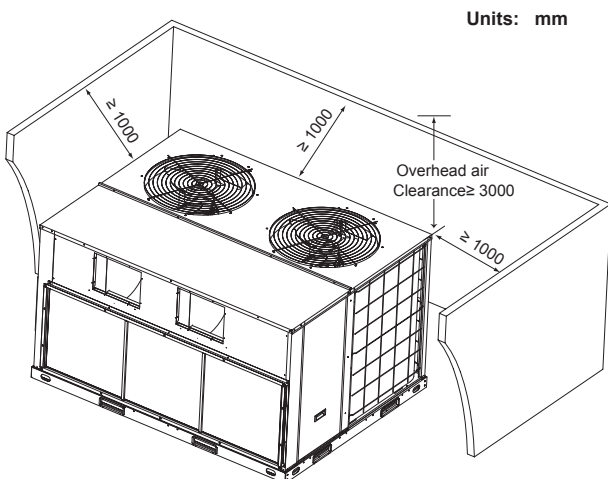

Fig.4-1

5. INSTALLATION

5.1 Lifting

- Rigging cables should have adequate capability to resist 3 times weight of unit. Before lift, please check and ensure that hooks are holding tightly to unit and lifting angles are no less than 60°. (See Fig. 5-1)
- Cloth material or hard-paper should be padded in the contact place between unit and rigging cable. Rigging cable should be entwined a round at the hook for prevent danger by cable slip because of weight unbalance.
- During lifting, anyone forbidden lingering under the lifting unit.

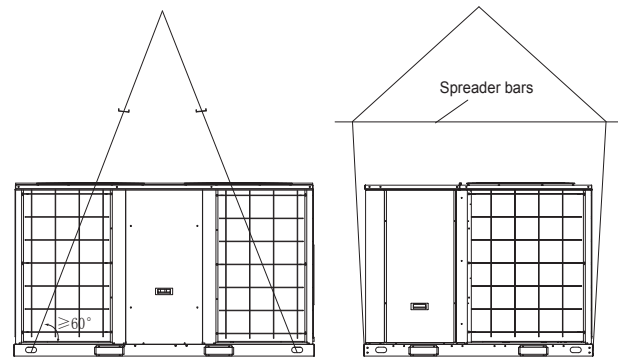

Fig.5-1

5.2 Rooftop-units

- **For roof top applications using a field fabricated frame and ducts, use the following procedure:**
- The frame must be located and secured by bolting or welding to the roof. Flashing is required.
- The hole in the roof must be prepared in advance of installing the unit.
- Secure the ducts to the roof.
- Place the unit on the frame or roof curb.
- Secure the unit to the frame or roof curb.
- Insulate any ductwork outside of the structure with at least 2 inches of insulation and then weatherproof. There must be a weatherproof seal where the duct enters the structure.
- Complete the installation according to the instructions in the following sections of this manual.
- Typical rooftop application with frame. (See Fig. 5-2)

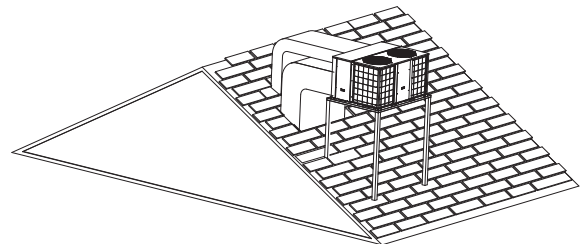

Fig.5-2

5.3 Ground level-horizontal units

- For ground level installations, the unit should be positioned on a pad in the size of the unit or larger. The unit must be level on the pad. The pad must not come in contact with the structure. Be sure the outdoor portion of the supply and return air ducts are as short as possible.
- Proceed with the installation as follows:
 - Place the unit on the pad.
 - Attach the supply and return air ducts to the unit.
 - Insulate any ductwork outside of the structure with at least 2 inches of insulation and weatherproof. There must be a weatherproof seal where the duct enters the structure.
 - Complete the installation according to the instructions in the following sections of this manual.
- Typical ground level application

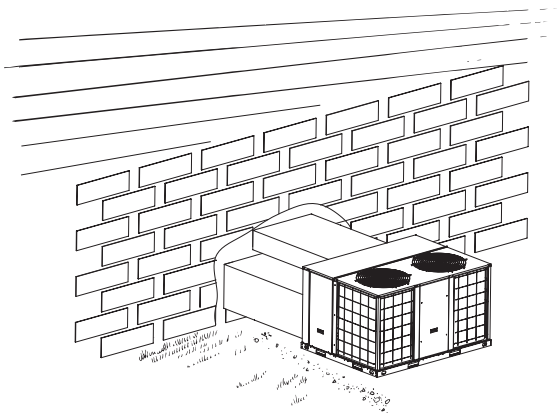

Fig.5-3

- Only use this unit in well-ventilated spaces and ensure that there are no obstructions that could impede the airflow into and out of the unit.

Do not use this unit in the following locations:

- Locations with mineral oil.
- Locations with saline atmospheres, such as seaside locations.
- Locations with sulphurous atmospheres, such as near natural hot springs.
- Where high voltage electricity is present, such as in certain industrial locations.
- On vehicles or vessels, such as trucks or ferry boats.
- Where exposure to oily or very humid air may occur, such as kitchens.
- In proximity to sources of electromagnetic radiation, such as high-frequency transmitters or other high strength radiation devices.

5.4 Condensate drain piping

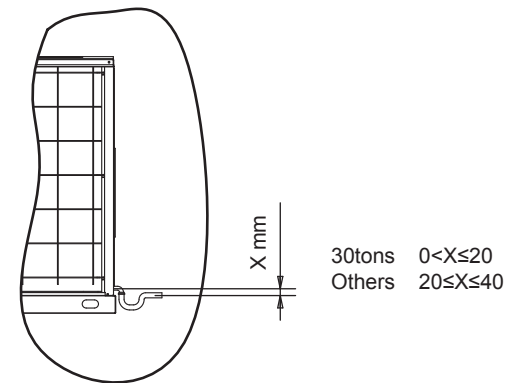
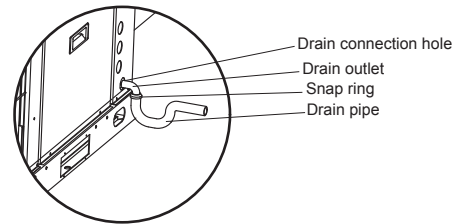
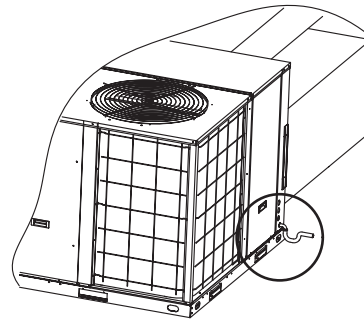

Fig.5-4

5.5 Ductwork

- Attaching horizontal ductwork to unit

All conditioned air ductwork should be insulated to minimize heating and cooling duct losses. Use a minimum of 2 inches of insulation with a vapor barrier. The outside ductwork must be weatherproofed between the unit and the building.

When attaching ductwork to a horizontal unit, provide a flexible watertight connection to prevent noise transmission from the unit to the ducts. The flexible connection must be indoors and made out of heavy canvas.



NOTE

Do not draw the canvas taut between the solid ducts.

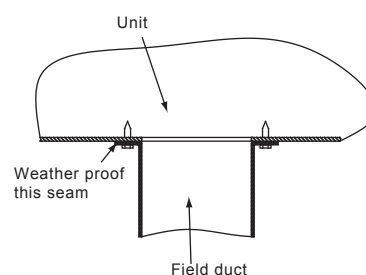

Fig.5-5

6. ELECTRICAL WIRING



WARNING

- An all-pole disconnection switch having a contact separation of at least 3mm in all poles should be connected in fixed wiring.
- The appliance shall be installed in accordance with national wiring regulations.
- An all-pole disconnection device which has at least 3mm separation distance in all pole and a residual current device(RCD)with the rating of above 10mA shall be incorporated in the fixed wiring according to the national rule.
- The appliance shall be installed in accordance with national wiring regulations.

6.1 Protections and safety control

- **Minutes delay for the compressor start-up**
At the beginning of energizing, 3-minutes delay should be taken to start the compressor. while after the stop of the compressor, 7-minutes delay should be taken to re-start the compressor.
- **Compressor discharge temperature protection**
When discharge temperature $>257^{\circ}\text{F}$, the compressor will stop.
- **Reverse phase protection relay**
 - The reverse phase protection relay will make the unit not start, when the power source is incorrectly connected.
 - The checking of phase order is just carried out at the first time of electrifying. If malfunction happens then the checking will be going on until the order of phase is right, and the E0 will be displayed on the board. If there is no problem in the first checking, then it will be omitted.
- **High pressure and low pressure protection**
When high pressure ≥ 638 Psi, and lower pressure ≤ 21 Psi, the unit will stop.

6.2 Electrical data

Tab.6-1

Model	Model type	Type of flow	Compressor				Evaporator fan motor			Condenser fan motor		
			STC	RNC	IPT	Qty	RNC	IPT	Qty	RNC (each)	IPT (each)	Qty
YMMRZC020 TAQ-B-X	C/O	Hor.	245	38	12.4	2	19.68	5.93	1	8.80	2.60	2
YMMRZC020 TAJ-B-X	C/O	Hor.	147	21.4	12.94	2	9.40	5.723	1	4.30	2.75	2
YMMRZC025 TAQ-B-X	C/O	Hor.	315	43.27	14.43	2	26.7	7.5	1	9	2.2	2
YMMRZC025 TAJ-B-X	C/O	Hor.	158	20.66	12.15	2	12.8	7.5	1	4.30	2.2	2



NOTES

- STC: Starting Current (A) RNC: Running Current (A) IPT: Input Power (kW) Qty: Quantity
- These data are based on the following conditions. Evaporator Air Input Temperature 89.6°F DB, 73.4°F WB. Condenser Air Input Temperature 125.6°F DB.

6.3 Wiring provision

■ **Field wiring**

The units are internally wired at the factory according to generally accepted electrical technology.

■ **Required field wiring**

Main power wiring to the unit control wiring between the control center and the unit, and earth wiring are required in the field.

■ **Required components**

The following components are required: main power fuses, conduit coupling, and field supplied room thermostat.

■ **Wire and fuse size selection for main power source**

Wire and fuse sizes should be selected in accordance with national and standard, taking the designed maximum current shall be the total of the compressor maximum current, condenser fan motor current and evaporator fan motor current(refer to “electrical data”).

■ **Wire size between room thermostat and unit**

The wire size between the room thermostat and the unit should be determined according to the following table, because the 24V power source is applied to the control circuit.

Tab.6-2

	Wiring length between room thermostat and unit(one way)				
	10m	15m	20m	30m	40m
Minimum wire size(mm ²)	0.5	0.5	0.75	0.75	1.0



NOTE

- Before connecting the device to the public low-voltage supply systems the permission of the electricity supplier is forcefully necessary.

6.4 Operating conditions

For proper performance, run the unit under the following temperature conditions:

Tab.6-3

Cooling operation	Outdoor temperature: 50°F to 125.6°F
	Room temperature: 62°F to 88°F
	Caution Room relative humidity less than 80%. If the unit operates in excess of this figure, the surface of the unit may attract condensation.

6.5 Main power supply

Tab.6-4

Model type	Unit main power	Main power switch	Fuse	Wires for Power supplies	Type of wires
YMMRZC020TAQ-B-X	220V 3N~ 60Hz	150A	125A	3x50mm ² +2x25mm ²	3xUL1015 1/0AWG 2xUL1015 3AWG
YMMRZC020TAJ-B-X	460V 3N~ 60Hz	90A	80A	3x25mm ² +2x10mm ²	3xUL1015 3AWG 2xUL1015 7AWG
YMMRZC025TAQ-B-X	220V 3N~ 60Hz	125A	125A	3x50mm ² +2x25mm ²	3xUL1015 1/0AWG 2xUL1015 3AWG
YMMRZC025TAJ-B-X	460V 3N~ 60Hz	70A	60A	3x15mm ² +2x10mm ²	3xUL1015 5AWG 2xUL1015 7AWG



NOTE

- The power supply designation is H07RN-F.

6.6 Control wiring

■ Power supply

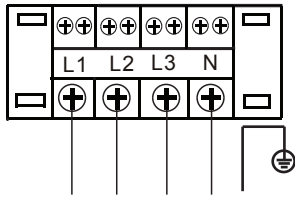

Fig. 6-1

Next wire joint also available

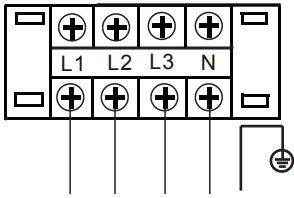
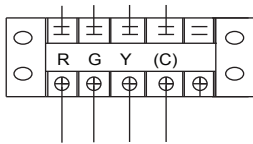

Fig. 6-2

■ To connect with wire controller

● For C/O Units



● For E/Heater+C Units

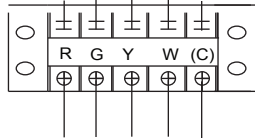

Suggestion: Thermostat choose KJR-23B or Non-programmed electrical thermostat series of Honeywell, such as TH 5220D. Wiring please refer to the Owner's Manual of the thermostat.

■ Dial code settings

Set the dial code SW3 of PCB in unit's wire control box, After settings, please shut off the power supply and then repower, otherwise, the new settings function couldn't work.

- When SW3 has been set in "ON", please select KJR-12B wire controller;
- When SW3 has been set in "1", please select KJR-23B wire controller, KJR-23B is optional.

● For C/O Units

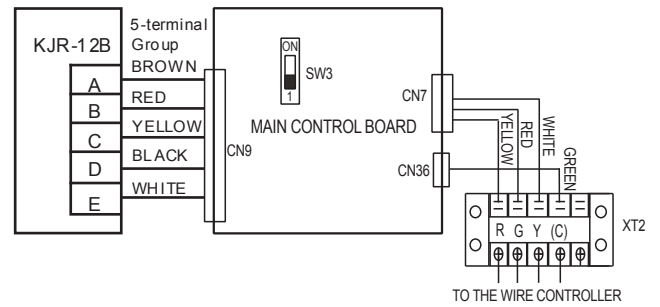

● For E/Heater+C Units

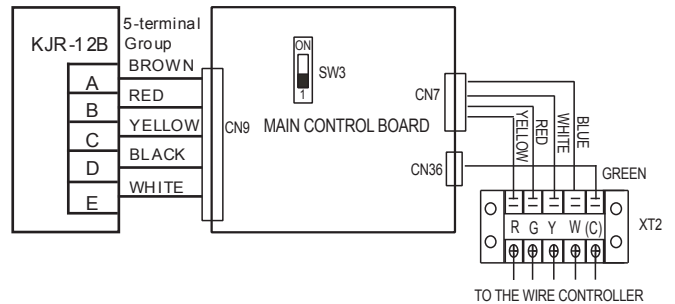

6.7 Error code

Type	Content	Code	Remarks
Normal	Standby	—	
Normal	Constraint cool	on	
Normal	Run	10.	
Error	Compressor phase sequence error or phase default	E0	
Error	Outdoor coil sensor in sys. A error	E1	
Error	Outdoor coil sensor in sys. B error	E2	
Error	Overcurrent protection of system A are active 3 times within one hour	E3	Unit shall be power off to recovery
Error	Overcurrent protection of system B are active 3 times within one hour	E4	Unit shall be power off to recovery
Error	Indoor coil sensor in sys. A error	E5	
Error	Indoor coil sensor in sys. B error	E6	
Error	High、 low pressure protection or discharge temperature protection of system A reached 3 times	E7	Unit shall be power off to recovery
Error	High、 low pressure protection or discharge temperature protection of system B reached 3 times	E8	Unit shall be power off to recovery
Error	Indoor sensor error	E9	
Error	Outdoor ambient sensor error	EA	
Error	Wire controller output error	Eb	
Error	EEPROM error	EE	
Protection	Overcurrent protection in sys.A	P0	
Protection	Overcurrent protection in sys.B	P1	
Protection	Overcurrent protection for indoor fan	P2	
Protection	Comprehensive protection for outdoor fan	P3	
Protection	Protection for Hi./Lo. pressure or exhaust temp. in sys.A	P4	Comprehensive protection in sys.A
Protection	Protection for Hi./Lo. pressure or exhaust temp. in sys.B	P5	Comprehensive protection in sys.B
Protection	Hi-pressure protection initiated in T2 evaporator stops the outdoor unit fan	P6	
Protection	Hi-pressure protection initiated in T2 evaporator stops the outdoor unit fan and compressor	P7	
Protection	Protection for condenser Hi-temp. in sys.A	P8	
Protection	Protection for condenser Hi-temp. in sys.B	P9	
Protection	Anti-freezing protection for evaporator in sys. A	Pc	
Protection	Anti-freezing protection for evaporator in sys. B	Pd	
Protection	Defrosting	dF	
Protection	Protection for outdoor temp	PA	

7. SPECIFICATION

7.1 Physical Data

Tab.7-1

Model		YMMRZC020TAQ-B-X	YMMRZC020TAJ-B-X	YMMRZC025TAQ-B-X	YMMRZC025TAJ-B-X
Model type		C/O	C/O	C/O	C/O
Type of flow		Hor.	Hor.	Hor.	Hor.
Capacity	Cooling capacity(net) (Btu/h) ⁽¹⁾	---	---	---	---
	Heating capacity (Btu/h)	---	---	---	---
Performance	EER	---	---	---	---
Dimensions	Length(mm)	2320	2320	2320	2320
	Width(mm)	2220	2220	2220	2220
	Height(mm)	1245	1245	1245	1245
Net weight(kg)		895	895	940	940
Refrigerant type		R410A	R410A	R410A	R410A
Flow control		Capillary	Capillary	Capillary	Capillary
Compressor	Quantity/Type	2/Scroll	2/Scroll	2/Scroll	2/Scroll
Outdoor coil	Rows	3+2	3+2	3	3
	Fins per inch	17	17	17	17
	Tube diameter(in.)	9/32	9/32	9/32	9/32
Indoor coil	Rows	4	4	4	4
	Fins per inch	16	16	16	16
	Tube diameter(in.)	5/16	5/16	5/16	5/16
Outdoor fan	Quantity used/diameter(mm)	2/800	2/800	2/800	2/800
	Type	Propeller	Propeller	Propeller	Propeller
	Drive type	Direct	Direct	Direct	Direct
	Quantity speeds	1	1	1	1
	Quantity motors/power(kW)	2/2.60	2/2.75	2/2.2	2/2.2
	Motor RPM	1130	1100	1130	1130
	Nominal total CFM	/	/	/	/
Indoor fan	Quantity used/model	1/SYD355R2-L	1/SYD355R2-L	1/YKSJ-7500-4-7(YES-132M-4)	1/YKSJ-7500-4-26(YES-132M-4)
	Type	FC Centrifugal	FC Centrifugal	FC Centrifugal	FC Centrifugal
	Drive type	Belt	Belt	Belt	Belt
	Quantity speeds	Variable sheave	Variable sheave	Variable sheave	Variable sheave
	Quantity motors/power(kW)	1/5.7(250Pa)	1/5.7(250Pa)	1/7.5(270Pa)	1/7.5(270Pa)
	Motor RPM	1730	1730	1730	1730
	Nominal total CFM ^(II)	11138	11500(250Pa)	11100(270Pa)	11100(270Pa)



NOTES

■ ⁽¹⁾ Cooling capacities are rated at 95°F ambient DB, 80°F entering DB, 67°F entering WB.

■ ^(II) Units are suitable for operation to ±20% of nominal CFM.

7.2 Parameter For Air Volume

- Parameter table for indoor unit air volume

BLOWER DRIVE OPTIONS						
NOMINAL TON	MOTOR			BLOWER		
	HP	RPM	PULLEY PITCH DIA. (INCH)	SPEED RANGE (RPM)		PULLEY PITCH DIA. (INCH)
				MINIMUM	MAXIMUM	
20 TON	10	1730	4.53~5.25	925	1088	7.87
25 TON	10	1730	4.29~5.24	1060	1293	7.09

Example for selection process:

The following data are the rated design points for model 25Ton 220V rooftop:

Air flow(CFM)=11222cfm

External static pressure(ESP)=1.0in.w.g

Fan speed(RPM)=1284

Power input(W)=7623

The no. of turns (N) =1.75

To increase the ESP to 1.2in.w.g, but maintain the airflow rate at 11222cfm, please follow the steps below:

Step 1: Selection of new desired point.

From the table data, select the point that can meet both of the requirements (ESP = 1.2in.w.g and airflow rate(near or equal to) = 11222cfm).

Step 2: Read Fan speed(RPM), Power input(W):

Air flow(CFM)=11115cfm

Fan speed(RPM)=1306

Power input(W)=8094

Step 3: Read number of turns for variable pitch pulley.

Similarly, use this RPM value to read the no. of turns (N) by referring to the table of 'Motor Variable Pitch Pulley Data'. The variable pitch pulley for motor shall be adjusted to this 'N' in order to achieve the desired point (ESP = 1.2in.w.g and airflow rate =11222cfm). For instance, from the table, no. of turns (N) =1 in order to get 11115cfm. First, adjust the motor pulley to 0 turns. Then, makes 1 turns on the pulley. Cross check the dimension 'X', which stands for regulation space of motor pulley. In this case, X =2.5mm.

YMMRZC020TAQ-B-X & YMMRZC020TAJ-B-X

External static pressure(ESP)	N	0	0.25	0.5	0.75	1	1.25	1.5	1.75	2	2.25	2.5	2.75	3
	X	0.5	1	1.5	2	2.5	3	3.5	4	4.5	5	5.5	6	6.5
0	Fan speed(RPM)	/	/	/	/	/	/	/	/	/	/	/	/	1172
	Power input(W)	/	/	/	/	/	/	/	/	/	/	/	/	8368
	Air flow (CFM)	/	/	/	/	/	/	/	/	/	/	/	/	13634
0.1	Fan speed(RPM)	/	/	/	/	/	/	/	/	/	/	/	/	1174
	Power input(W)	/	/	/	/	/	/	/	/	/	/	/	/	8191
	Air flow (CFM)	/	/	/	/	/	/	/	/	/	/	/	/	13419
0.2	Fan speed(RPM)	/	/	/	/	/	/	/	/	/	/	/	1188	1174
	Power input(W)	/	/	/	/	/	/	/	/	/	/	/	8028	7900
	Air flow (CFM)	/	/	/	/	/	/	/	/	/	/	/	13235	13095
0.3	Fan speed(RPM)	/	/	/	/	/	/	/	/	/	/	/	1189	1175
	Power input(W)	/	/	/	/	/	/	/	/	/	/	/	7802	7674
	Air flow (CFM)	/	/	/	/	/	/	/	/	/	/	/	12938	12800
0.4	Fan speed(RPM)	/	/	/	/	/	/	/	/	/	/	1185	1180	1176
	Power input(W)	/	/	/	/	/	/	/	/	/	/	7453	7450	7447
	Air flow (CFM)	/	/	/	/	/	/	/	/	/	/	12592	12549	12505
0.5	Fan speed(RPM)	/	/	/	/	/	/	/	/	/	1215	1185	1181	1176
	Power input(W)	/	/	/	/	/	/	/	/	/	7350	7164	7155	7146
	Air flow (CFM)	/	/	/	/	/	/	/	/	/	12552	12275	12208	12141
0.6	Fan speed(RPM)	/	/	/	/	/	/	/	/	1225	1216	1186	1181	1177
	Power input(W)	/	/	/	/	/	/	/	/	8405	7032	6874	6860	6845
	Air flow (CFM)	/	/	/	/	/	/	/	/	12706	12210	11958	11867	11777
0.7	Fan speed(RPM)	/	/	/	/	/	/	/	1230	1220	1216	1187	1183	1178
	Power input(W)	/	/	/	/	/	/	/	6950	6846	6742	6607	6589	6571
	Air flow (CFM)	/	/	/	/	/	/	/	12704	12377	11835	11597	11500	11402
0.8	Fan speed(RPM)	/	/	/	/	/	/	1230	1225	1220	1217	1188	1184	1180
	Power input(W)	/	/	/	/	/	/	8379	8203	7854	6452	6339	6318	6297
	Air flow (CFM)	/	/	/	/	/	/	12654	12423	12048	11460	11237	11132	11028
0.9	Fan speed(RPM)	/	/	/	/	/	1215	1210	1200	1200	1189	1185	1183	1181
	Power input(W)	/	/	/	/	/	8155	8124	7923	7573	6195	6090	6062	6033
	Air flow (CFM)	/	/	/	/	/	12362	12352	12092	11671	11140	10926	10773	10620
1	Fan speed(RPM)	/	/	/	1220	1215	1214	1209	1200	1200	1189	1185	1182	1182
	Power input(W)	/	/	/	8696	8497	7868	7868	7643	7292	5938	5841	5805	5769
	Air flow (CFM)	/	/	/	12321	12063	12045	12050	11762	11294	10821	10615	10413	10212
1.1	Fan speed(RPM)	/	/	1220	1218	1213	1210	1207	1199	1199	1188	1182	1181	/
	Power input(W)	/	/	8383	8404	8195	6473	6463	6317	5952	5779	5693	5768	/
	Air flow (CFM)	/	/	11957	11970	11681	11553	11509	11280	10792	10452	10300	10200	/
1.2	Fan speed(RPM)	/	1220	1218	1215	1210	1208	1205	1197	1197	1188	1181	/	/
	Power input(W)	/	8566	8077	8111	7892	6495	6475	6409	6029	5843	5768	/	/
	Air flow (CFM)	/	12174	11596	11619	11299	11308	11215	11045	10536	10098	9999	/	/
1.3	Fan speed(RPM)	/	1218	1215	1212	1208	1206	1203	1195	1191	1186	/	/	/
	Power input(W)	/	8576	8216	8117	7892	6186	6316	5915	5870	5939	/	/	/
	Air flow (CFM)	/	12402	11891	11681	11299	10418	10847	9838	10168	9105	/	/	/
1.4	Fan speed(RPM)	1220	1215	1213	1210	1206	1201	1200	1188	1178	/	/	/	/
	Power input(W)	8629	7946	7715	7484	7253	6250	6380	5979	5934	/	/	/	/
	Air flow (CFM)	11462	11818	11374	10931	10487	10034	9605	9356	9025	/	/	/	/
1.5	Fan speed(RPM)	1215	1211	1210	1209	1205	1201	1200	1189	/	/	/	/	/
	Power input(W)	8342	8575	8809	7967	7126	6123	6253	5852	/	/	/	/	/
	Air flow (CFM)	11076	11514	11952	11069	10187	9733	9304	9055	/	/	/	/	/
1.6	Fan speed(RPM)	1206	1204	1201	1201	1200	1196	1189	/	/	/	/	/	/
	Power input(W)	8055	8011	7967	7791	6999	5996	6126	/	/	/	/	/	/
	Air flow (CFM)	10689	10656	10622	10489	9886	9433	9004	/	/	/	/	/	/
1.7	Fan speed(RPM)	1200	1200	1196	1196	1189	1186	/	/	/	/	/	/	/
	Power input(W)	5571	5615	5659	5835	6627	5624	/	/	/	/	/	/	/
	Air flow (CFM)	8441	8474	8508	8642	9244	8791	/	/	/	/	/	/	/
1.8	Fan speed(RPM)	1186	1184	1184	1184	1180	1180	/	/	/	/	/	/	/
	Power input(W)	7310	7266	7222	7046	6254	5251	/	/	/	/	/	/	/
	Air flow (CFM)	9406	9373	9339	9205	8603	8150	/	/	/	/	/	/	/

Legend: X: Regulation Space of Motor Pulley (mm); N: Number of Turns; ESP: External Static Pressure (in.w.g)

External static pressure(ESP)	N	0	0.25	0.5	0.75	1	1.25	1.5	1.75	2	2.25	2.5	2.75	3
	X	0.5	1	1.5	2	2.5	3	3.5	4	4.5	5	5.5	6	6.5
0	Fan speed(RPM)	/	/	/	/	/	/	/	/	/	/	1257	1249	1241
	Power input(W)	/	/	/	/	/	/	/	/	/	/	9193	8828	8442
	Air flow(CFM)	/	/	/	/	/	/	/	/	/	/	13959	13782	13515
0.1	Fan speed(RPM)	/	/	/	/	/	/	/	/	/	/	1258	1250	1242
	Power input(W)	/	/	/	/	/	/	/	/	/	/	8912	8559	8195
	Air flow(CFM)	/	/	/	/	/	/	/	/	/	/	13618	13441	13220
0.2	Fan speed(RPM)	/	/	/	/	/	/	/	/	/	/	1259	1251	1243
	Power input(W)	/	/	/	/	/	/	/	/	/	/	8631	8290	7948
	Air flow(CFM)	/	/	/	/	/	/	/	/	/	/	13277	13101	12924
0.3	Fan speed(RPM)	/	/	/	/	/	/	/	/	/	/	1260	1252	1244
	Power input(W)	/	/	/	/	/	/	/	/	/	/	8350	8021	7691
	Air flow(CFM)	/	/	/	/	/	/	/	/	/	/	12936	12760	12584
0.4	Fan speed(RPM)	/	/	/	/	/	/	/	/	/	/	1266	1261	1253
	Power input(W)	/	/	/	/	/	/	/	/	/	/	8387	8069	7752
	Air flow(CFM)	/	/	/	/	/	/	/	/	/	/	12771	12595	12419
0.5	Fan speed(RPM)	/	/	/	/	/	/	/	/	/	/	1267	1262	1254
	Power input(W)	/	/	/	/	/	/	/	/	/	/	8151	7832	7513
	Air flow(CFM)	/	/	/	/	/	/	/	/	/	/	12475	12292	12109
0.6	Fan speed(RPM)	/	/	/	/	/	/	/	/	1273	1268	1263	1255	1247
	Power input(W)	/	/	/	/	/	/	/	/	8432	8014	7595	7275	6954
	Air flow(CFM)	/	/	/	/	/	/	/	/	12478	12234	11989	11800	11610
0.7	Fan speed(RPM)	/	/	/	/	/	/	/	1281	1274	1269	1264	1256	1248
	Power input(W)	/	/	/	/	/	/	/	8583	8157	7732	7306	7003	6701
	Air flow(CFM)	/	/	/	/	/	/	/	16854	15108	13361	11615	11422	11230
0.8	Fan speed(RPM)	/	/	/	/	/	/	1289	1282	1275	1270	1265	1257	1249
	Power input(W)	/	/	/	/	/	/	8483	8183	7882	7450	7017	6732	6447
	Air flow(CFM)	/	/	/	/	/	/	12122	14930	17737	14489	11241	11045	10849
0.9	Fan speed(RPM)	/	/	/	/	/	1296	1290	1283	1276	1271	1266	1258	1250
	Power input(W)	/	/	/	/	/	8506	8205	7903	7601	7188	6774	6480	6186
	Air flow(CFM)	/	/	/	/	/	10474	11775	13076	14377	12635	10893	10670	10447
1.0	Fan speed(RPM)	/	/	/	/	1304	1297	1291	1284	1277	1272	1267	1259	1251
	Power input(W)	/	/	/	/	8669	8298	7926	7623	7320	6926	6531	6228	5924
	Air flow(CFM)	/	/	/	/	11908	11668	11427	11222	11016	10780	10544	10295	10045
1.1	Fan speed(RPM)	/	/	/	/	1305	1298	1292	1285	1278	1273	1268	1260	1252
	Power input(W)	/	/	/	/	8382	8006	7630	7339	7048	6650	6252	5955	5659
	Air flow(CFM)	/	/	/	/	11512	11234	10957	10805	10653	10398	10143	9883	9623
1.2	Fan speed(RPM)	/	/	1320	1313	1306	1299	1293	1286	1279	1274	1269	1261	1253
	Power input(W)	/	/	8896	8495	8094	7714	7334	7055	6775	6374	5972	5683	5393
	Air flow(CFM)	/	/	11726	11421	11115	10801	10486	10388	10290	10016	9742	9472	9201
1.3	Fan speed(RPM)	/	/	1321	1314	1307	1300	1294	1287	1280	1275	1270	1262	1254
	Power input(W)	/	/	8593	8183	7773	7419	7064	6766	6468	6074	5680	5398	5117
	Air flow(CFM)	/	/	11298	11019	10741	10438	10135	9990	9845	9527	9210	8959	8709
1.4	Fan speed(RPM)	/	/	1322	1315	1308	1301	1295	1288	1281	1276	1271	1263	1255
	Power input(W)	/	/	8290	7871	7452	7123	6794	6477	6160	5774	5387	5114	4840
	Air flow(CFM)	/	/	10870	10618	10366	10075	9783	9591	9399	9039	8678	8447	8216
1.5	Fan speed(RPM)	/	1328	1323	1316	1309	1302	1296	1289	1282	0	0	0	0
	Power input(W)	/	8384	7985	7585	7186	6833	6480	6149	5819	0	0	0	0
	Air flow(CFM)	/	10712	10448	10183	9919	9598	9278	9034	8790	0	0	0	0
1.6	Fan speed(RPM)	1336	1330	1324	1317	1310	1303	1297	1290	1283	0	0	0	0
	Power input(W)	8499	8089	7679	7300	6920	6543	6165	5822	5478	0	0	0	0
	Air flow(CFM)	10628	10327	10025	9748	9471	9122	8773	8477	8180	0	0	0	0
1.7	Fan speed(RPM)	1337	1331	1325	1318	1311	0	0	0	0	0	0	0	0
	Power input(W)	8185	7762	7340	6979	6618	0	0	0	0	0	0	0	0
	Air flow(CFM)	10197	9873	9549	9257	8966	0	0	0	0	0	0	0	0
1.8	Fan speed(RPM)	1338	1332	1326	1319	1312	0	0	0	0	0	0	0	0
	Power input(W)	7870	7436	7001	6658	6315	0	0	0	0	0	0	0	0
	Air flow(CFM)	9765	9419	9072	8767	8461	0	0	0	0	0	0	0	0
1.9	Fan speed(RPM)	1339	0	0	0	0	0	0	0	0	0	0	0	0
	Power input(W)	7380	0	0	0	0	0	0	0	0	0	0	0	0
	Air flow(CFM)	8965	0	0	0	0	0	0	0	0	0	0	0	0
2.0	Fan speed(RPM)	1340	0	0	0	0	0	0	0	0	0	0	0	0
	Power input(W)	6980	0	0	0	0	0	0	0	0	0	0	0	0
	Air flow(CFM)	8165	0	0	0	0	0	0	0	0	0	0	0	0

Legend: X: Regulation Space of Motor Pulley (mm); N: Number of Turns; ESP: External Static Pressure(in.w.g)

External static pressure(ESP)	N	0	0.25	0.5	0.75	1	1.25	1.5	1.75	2	2.25	2.5	2.75	3
	X	0.5	1	1.5	2	2.5	3	3.5	4	4.5	5	5.5	6	6.5
0	Fan speed(RPM)	/	/	/	/	/	/	/	/	/	/	1258	1249	1242
	Power input(W)	/	/	/	/	/	/	/	/	/	/	8572	8274	7975
	Air flow(CFM)	/	/	/	/	/	/	/	/	/	/	13826	13130	13489
0.1	Fan speed(RPM)	/	/	/	/	/	/	/	/	/	/	1258	1250	1242
	Power input(W)	/	/	/	/	/	/	/	/	/	/	8379.5	8065	7750
	Air flow(CFM)	/	/	/	/	/	/	/	/	/	/	13576	13387	13199
0.2	Fan speed(RPM)	/	/	/	/	/	/	/	/	/	/	1259	1252	1243
	Power input(W)	/	/	/	/	/	/	/	/	/	/	8187	7856	7525
	Air flow(CFM)	/	/	/	/	/	/	/	/	/	/	13325	13117	12909
0.3	Fan speed(RPM)	/	/	/	/	/	/	/	/	/	/	1260	1252	1244
	Power input(W)	/	/	/	/	/	/	/	/	/	/	7963.5	7621	7278
	Air flow(CFM)	/	/	/	/	/	/	/	/	/	/	13032	12785	12537
0.4	Fan speed(RPM)	/	/	/	/	/	/	/	/	/	/	1266	1261	1253
	Power input(W)	/	/	/	/	/	/	/	/	/	/	8365	7740	7385
	Air flow(CFM)	/	/	/	/	/	/	/	/	/	/	13167	12739	12452
0.5	Fan speed(RPM)	/	/	/	/	/	/	/	/	/	/	1267	1262	1254
	Power input(W)	/	/	/	/	/	/	/	/	/	/	8093	7485	7134
	Air flow(CFM)	/	/	/	/	/	/	/	/	/	/	12818	12414	12111
0.6	Fan speed(RPM)	/	/	/	/	/	/	/	/	1273	1268	1263	1255	1247
	Power input(W)	/	/	/	/	/	/	/	/	8412	7821	7230	6882	6534
	Air flow(CFM)	/	/	/	/	/	/	/	/	12850	12469	12088	11770	11451
0.7	Fan speed(RPM)	/	/	/	/	/	/	/	1281	1274	1269	1264	1256	1250
	Power input(W)	/	/	/	/	/	/	/	8405.25	8134	7554	6974	6634	6294
	Air flow(CFM)	/	/	/	/	/	/	/	12639	12507	12105	11704	11393	11083
0.8	Fan speed(RPM)	/	/	/	/	/	/	1289	1282	1275	1270	1265	1256	1249
	Power input(W)	/	/	/	/	/	/	8398	8127	7856	7287	6718	6386	6054
	Air flow(CFM)	/	/	/	/	/	/	12441	12302	12163	11741	11319	11017	10715
0.9	Fan speed(RPM)	/	/	/	/	/	1296	1290	1283	1276	1271	1267	1258	1250
	Power input(W)	/	/	/	/	/	8480	8109	7840	7571	7014	6458	6125	5792
	Air flow(CFM)	/	/	/	/	/	12323	12089	11946	11804	11374	10944	10627	10311
1.0	Fan speed(RPM)	/	/	/	/	1304	1297	1291	1284	1277	1273	1267	1259	1251
	Power input(W)	/	/	/	/	8559	8190	7820	7553	7285	6741	6197	5863	5529
	Air flow(CFM)	/	/	/	/	12230	11983	11736	11590	11444	11006	10568	10237	9906
1.1	Fan speed(RPM)	/	/	/	/	1305	1298	1292	1285	1279	1273	1268	1260	1252
	Power input(W)	/	/	/	/	8255	7890.25	7526	7261	7012	6466	5921	5593	5266
	Air flow(CFM)	/	/	/	/	11844	11591	11338	11201	11064	10598	10132	9788	9445
1.2	Fan speed(RPM)	/	/	/	/	1306	1299	1294	1287	1279	1274	1269	1261	1253
	Power input(W)	/	/	/	/	7951	7591	7231	6985	6738	6192	5645	5324	5002
	Air flow(CFM)	/	/	/	/	11458	11199	10939	10812	10684	10190	9695	9339	8984
1.3	Fan speed(RPM)	/	/	/	1314	1308	1300	1294	1287	1280	1275	1270	1262	1254
	Power input(W)	/	/	/	8080	7645	7289	6933	6687	6441	5894	5347	5019	4691
	Air flow(CFM)	/	/	/	11348	11071	10800	10530	10357	10185	9674	9163	8795	8428
1.4	Fan speed(RPM)	/	/	1322	1315	1308	1301	1295	1288	1281	1276	1271	1263	1255
	Power input(W)	/	/	8191	7765	7339	6987	6634	6389	6143	5596	5048	4714	4379
	Air flow(CFM)	/	/	11264	10974	10684	10402	10120	9903	9685	9158	8630	8252	7873
1.5	Fan speed(RPM)	/	1328	1324	1316	1309	1302	1296	1289	1282	0	0	0	0
	Power input(W)	/	8169.75	7861.5	7441	7021	6635	6249	6020	5792	0	0	0	0
	Air flow(CFM)	/	11085	10844	10536	10228	9836	9444	9232	9021	0	0	0	0
1.6	Fan speed(RPM)	1337	1330	1324	1317	1310	1303	1297	1290	1283	0	0	0	0
	Power input(W)	8121	7827	7532	7117	6702	6283	5864	5652	5440	0	0	0	0
	Air flow(CFM)	10927	10676	10424	10098	9772	9270	8767	8562	8357	0	0	0	0
1.7	Fan speed(RPM)	1337	1331	1325	0	0	0	0	0	0	0	0	0	0
	Power input(W)	7727	7455	7184	0	0	0	0	0	0	0	0	0	0
	Air flow(CFM)	10450	10171	9892	0	0	0	0	0	0	0	0	0	0
1.8	Fan speed(RPM)	1338	1332	1326	0	0	0	0	0	0	0	0	0	0
	Power input(W)	7332	7084	6835	0	0	0	0	0	0	0	0	0	0
	Air flow(CFM)	9972	9666	9360	0	0	0	0	0	0	0	0	0	0
1.9	Fan speed(RPM)	1340	0	0	0	0	0	0	0	0	0	0	0	0
	Power input(W)	6874	0	0	0	0	0	0	0	0	0	0	0	0
	Air flow(CFM)	9143	0	0	0	0	0	0	0	0	0	0	0	0
2.0	Fan speed(RPM)	1342	0	0	0	0	0	0	0	0	0	0	0	0
	Power input(W)	6415	0	0	0	0	0	0	0	0	0	0	0	0
	Air flow(CFM)	8314	0	0	0	0	0	0	0	0	0	0	0	0

Legend: X: Regulation Space of Motor Pulley (mm); N: Number of Turns; ESP: External Static Pressure(in.w.g)

Bold data is the performance testing set point, Shading data are rated airflow.

8. START-UP

■ Before starting unit

- Is the unit properly located and level with the proper clearance?
- Is the duct work correctly sized, run, taped, insulated, and weatherproofed with proper unit arrangement? See Ductwork Installation section.
- Is the wiring properly sized and run according to the unit wiring diagram?
- Are all the wiring connections, including those in the unit, tight?
- Has the unit been properly grounded and fused with the recommended fuse size? See Wiring Data.
- Have the air conditioning systems been checked at the service ports for charge and leak tested if necessary?
- Does the condenser fan and indoor blower fan free without rubbing, and are they tight on the shafts?
- Are all covers and access panels in place to prevent air loss and safety hazards?

■ Starting the unit in the cooling mode

■ Voltage

With the unit operating, check the line voltage of the unit. The voltage should be within the range shown on the unit nameplate.

If low voltage is encountered, check the size and length of the supply line from the main disconnect to the unit. The line may be undersized for the length of the run.

■ Cooling shut down

Place the system selector in the OFF position or reset thermostat at a setting above room temperature.

Do not de-energize the main power disconnect except when unit is to be serviced.

9. MAINTENANCE

■ Regular maintenance

Some regular maintenance have been carry on by user, includes: change the one-time dust filter, clean casing, wash condenser and replace a new belt, as well as do some test for the equipment.

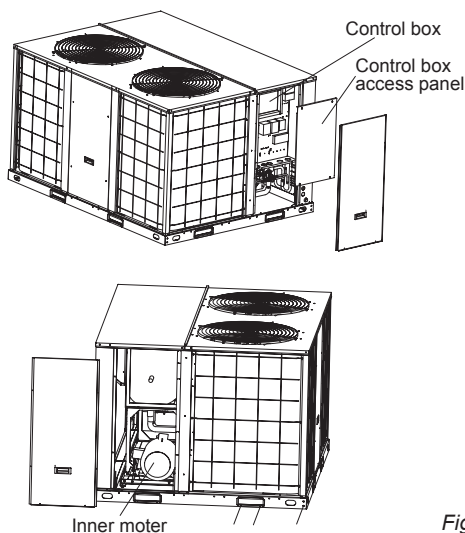

Fig.9-1



WARNING

At least 1m flame resistant layer must be laid at the end of the air duct internal surface.

■ Regulating belt of tension

Refer to Fig.9-3, loose 2 bolts, and move the electric motor to adjust belt tension.

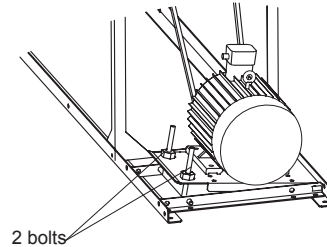

The two bolts are used for precision adjustment .

Fig.9-3

■ Belt tension is measured by belt tension indicator

- Calculate the deflection, deflection=A/64.
- Measure the belt deflection force, the force should be between the values shown in Tab.9-2

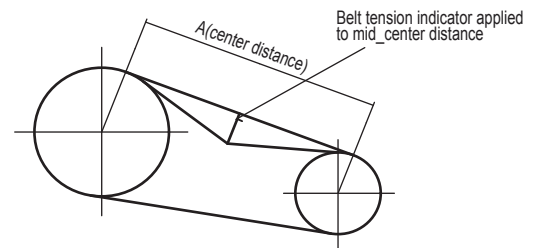

Fig.9-4

Tab.9-1

A (mm)
480

Tab.9-2

Belt section	For required to deflection		
	Small pulley diameter (mm)	Newton(N)	Kilogram-force(kgf)
SPA	80 to132	25 to 35	2.5 to 3.6



NOTE

The belt which is too tight or too loose may generate noise and be harmful to the unit.

- If you use air filter accessories provided by the manufacturer, please dismantle the air filter as the following steps.
 - Twist of screws and get out the plate.
 - Pull out the filter along the supporting slot.

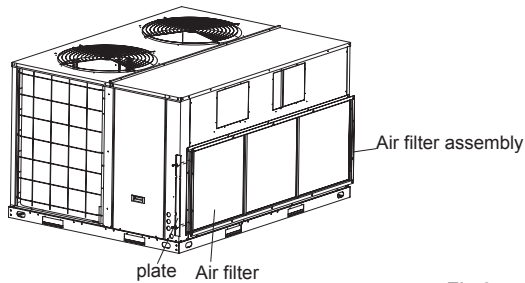

Fig.9-5

- Clean the air filter (Vacuum cleaner or fresh water may be used to clean the air filter. If the dust accumulated too much, please use soft brush and mild detergent to clean and dry out in cool place) .

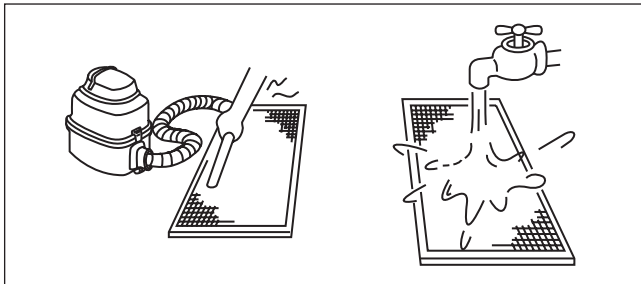

Fig.9-6

- The air-in side should face up when using vacuum cleaner.
- The air-in side should face down when using water.



CAUTION

Do not dry out the air filter under direct sunshine or heat.

- Re-install the air filter
- Condenser coil
Unfiltered air circulates through the unit's condenser coil can cause the coil's surface to become clogged with dust, etc. Clean the coil, vertically (i.e., with the fins), and stroke the coil surface with a soft brush. Be sure to keep all vegetation away from the condenser coil area.
- Maintenance performed by serviceman.
To keep your unit operating safely and efficiently, the manufacturer recommends that a qualified serviceman check the entire system at least once each year and any other time that you feel one is needed. Your serviceman should examine these areas of your unit:
- Filters
- Motors and drive system components
- Economizer gaskets (for possible replacement)
- Safety controls (for mechanical cleaning)
- Electrical components and wiring (for possible replacement and connection tightness)
- Condensate drain (for cleaning)
- Unit duct connections (to see that they are physically sound and sealed to the unit casing)
- Unit mounting support (for structural integrity)
- The unit (for obvious unit deterioration)



CAUTION

- Do not operate the unit without the evaporator fan access panel in place. Reinstall the access panel after performing any maintenance. Operating the unit without the access panel may result in severe personal injury or death.
- This unit is not intended for use by persons (including children) with reduced physical, sensory or mental capabilities, or lack of experience and knowledge, unless they have been given supervision or instruction concerning use of the appliance by a person responsible for their safety. Children should be supervised to ensure that they do not play with the unit.
- Disconnect the power supply before cleaning and maintenance.
- The unit shall be installed in accordance with national wiring regulations.



DISPOSAL: Do not dispose this product as unsorted municipal waste. Collection of such waste separately for special treatment is necessary.

- Do not dispose of electrical appliances as unsorted municipal waste, use separate collection facilities.
- Contact you local government for information regarding the collection systems available.
- If electrical appliances are disposed of in landfills or dumps, hazardous substances can leak into the groundwater and get into the food chain, damaging your health and well-being.

