

LEAD MATERIAL  
 18 GA. 2/64 INSUL. 125° C.  
 X-LINKED POLYETHYLENE  
 (2) BLACK,  
 55.00/51.00 [1397.0/1295.4]  
 W/ STRIP .56/.44 [14.2/11.2]  
 (2) BROWN,  
 7.00/5.00 [177.8/ 127.0]  
 W/ FFLAG TERMINAL  
 AMP 42742-2  
 (1) GRN/YEL,  
 15.00/14.00 [381.0/355.6]  
 W/ RING TERMINAL  
 AMP 60625-1

- NOTES:  
 1. MOTOR MEETS VDE SPECIFICATIONS.  
 2. MOTOR HAS 416 S.S. SHAFT.  
 3. NO PACKAGING TAPE OVER CARTON LABEL.

|                                               |            |               |           |                  |         |                    |        |        |        |      |       |
|-----------------------------------------------|------------|---------------|-----------|------------------|---------|--------------------|--------|--------|--------|------|-------|
| CUSTOMER:                                     | HEATCRAFT  | APPLICATION:  |           |                  |         |                    |        |        |        |      |       |
| CUSTOMER PN:                                  | 25309101   | MOTOR WEIGHT: | 4.50 LBS. |                  |         |                    |        |        |        |      |       |
| UP                                            |            | ENVIRONMENT:  | DRY       |                  |         |                    |        |        |        |      |       |
| HORIZONTAL                                    | MOTOR TYPE |               |           | REFERENCE SAMPLE |         |                    |        |        |        |      |       |
|                                               | P.S.C.     |               |           |                  |         |                    |        |        |        |      |       |
| DOWN                                          | B<br>00    | LA<br>90      | FR<br>30  | A<br>V           | S<br>05 | C<br>ON            | E<br>5 | B<br>3 | A<br>0 |      |       |
| TYPICAL PERFORMANCE AT 208-230 VOLTS 50/60 HZ |            |               |           |                  |         | CAP: 4 MFD/370 VAC |        |        |        |      |       |
| MOTOR SPEED                                   | RPM        | AMP           | WATT      | IN OZ            | RPM     | AMP                | WATT   | IN OZ  | AMP    | WATT | BREAK |
| 208/50                                        | 1479       | .25           | 47        | 29.1             | 1400    | .33                | 69     | 17.8   | .76    | 157  | 54.4  |
| 208/60                                        | 1778       | .20           | 40        | 42.2             | 1550    | .46                | 92     | 17.7   | .70    | 141  | 45.9  |
| 230/50                                        | 1480       | .30           | 63        | 34.3             | 1400    | .37                | 84     | 21.7   | .82    | 189  | 65.5  |
| 230/60                                        | 1781       | .24           | 53        | 50.2             | 1550    | .48                | 108    | 22.0   | .75    | 171  | 56.7  |

61305568

**SAFETY WARNING**  
 This motor must be grounded in accordance with local or national electrical codes to prevent possible injury due to electrical shock

**AVERTISSEMENT DE SÉCURITÉ**  
 Ce moteur doit être fondée sur conformément à la réglementation locale ou national électrique codes pour prévenir d'éventuelles blessures en raison de choc électrique

⚡

00464537

00469133

**FASCO™**  
 Assembled in Mexico  
 No. 71903004 TYPE U90B1 T.P. AO  
 208-230 V 50/60 Hz Class B  
 0.4/0.5 A 1400/1550 RPM 1/20/1/15 HP  
 Model D1123 E40513

Connection Diagram  
 Blk — Line  
 Blk — Line  
 Brn —  
 Grn/Yel — Grd  
 4 MFD/370 VAC

61299553

APPLY IN A CONVENIENT LOCATION TO READ FROM BACK END

|                                                                                                                                                                                                                                                                                                                                                                                                                                                                                                                                                                                                                                                                                      |                    |                             |                                                                                                                                                                                                 |                    |                                                    |
|--------------------------------------------------------------------------------------------------------------------------------------------------------------------------------------------------------------------------------------------------------------------------------------------------------------------------------------------------------------------------------------------------------------------------------------------------------------------------------------------------------------------------------------------------------------------------------------------------------------------------------------------------------------------------------------|--------------------|-----------------------------|-------------------------------------------------------------------------------------------------------------------------------------------------------------------------------------------------|--------------------|----------------------------------------------------|
| DRAWING REVISION<br>GB                                                                                                                                                                                                                                                                                                                                                                                                                                                                                                                                                                                                                                                               | REVISION BY<br>SDM | REV DATE/DATE<br>10/12/2022 | TOLERANCES (EXCEPT AS NOTED):<br>DEC. INCH mm ANGLE<br>.X ±0.1 [±3] ±1°<br>.XX ±0.01 [±0.3]<br>.XXX ±0.005 [±0.13]<br>.XXXX ±0.0005 [±0.013]                                                    | DRAWN BY<br>RPT    | <b>Regal Rexnord</b><br>Regal Beloit America, Inc. |
| REQUEST NUMBER<br>ECR-0221356                                                                                                                                                                                                                                                                                                                                                                                                                                                                                                                                                                                                                                                        | APPROVED BY<br>MLS | DATE<br>10/12/2022          | REMOVE BURRS & BREAK SHARP EDGES: .003/.015 [ .08/.38] X 45°<br>CORNER FILLETS: R.02 [ .5]<br>MACHINED SURFACES: ±.125 / mm 3.2 INCH / mm<br>mm DIMENSIONS IN [BRACKETS] ARE FOR REFERENCE ONLY | DATE<br>11/05/2015 |                                                    |
| REQUEST NUMBER DESCRIPTION<br>CHANGE NAMEPLATE FASCO LOGO TO FASCO TM                                                                                                                                                                                                                                                                                                                                                                                                                                                                                                                                                                                                                |                    |                             | DESCRIPTION<br><b>OUTLINE MOTOR ASSY</b>                                                                                                                                                        | APPROVED BY<br>JMG | PROCESS/FINISH<br>BLACK                            |
| COPYRIGHT (PER REVISION DATE) REGAL BELOIT AMERICA, INC. ALL RIGHTS RESERVED. PROPRIETARY AND CONFIDENTIAL INFORMATION - THIS DOCUMENT IS THE PROPERTY OF REGAL BELOIT AMERICA, INC. ("OWNER") AND CONTAINS OWNER'S PROPRIETARY INFORMATION. ANY PERSON, CORPORATION OR OTHER FIRM RECEIVING IT IS DEEMED, BY RECEIVING IT, TO AGREE THAT IT, AND/OR ANY PART OF IT, SHALL NOT BE DISCLOSED TO ANY PERSON, CORPORATION OR OTHER ENTITY, DUPLICATED, AND/OR USED, EXCEPT AS EXPRESSLY APPROVED IN WRITING IN ADVANCE BY OWNER. THIS DOCUMENT SHALL BE RETURNED TO OWNER UPON REQUEST. IT MAY BE SUBJECT TO CERTAIN RESTRICTIONS UNDER APPLICABLE EXPORT CONTROL LAWS AND REGULATIONS. |                    |                             | DATE<br>11/05/2015                                                                                                                                                                              | REFERENCE          |                                                    |
|                                                                                                                                                                                                                                                                                                                                                                                                                                                                                                                                                                                                                                                                                      |                    |                             | THIRD ANGLE PROJECTION                                                                                                                                                                          | SIZE<br>C          | DRAWING NUMBER<br>71903004                         |
|                                                                                                                                                                                                                                                                                                                                                                                                                                                                                                                                                                                                                                                                                      |                    |                             |                                                                                                                                                                                                 |                    | SHEET<br>1 OF 2                                    |

NOTES:

- 1. STAKE STATOR TO SLEEVE PER 88830264.
- 2. MAXIMUM TORQUE REQUIRED TO TURN MOTOR SHAFT IS 3/8 IN. OZ.
- 3. MAKE UP WASHERS ARE TO BE ADDED OR DELETED TO ACHIEVE REQUIRED ENDPLAY.
- 4. ASSEMBLE LOCK WASHER BETWEEN CAPACITOR BRACKET AND MOTOR.

FRONT END

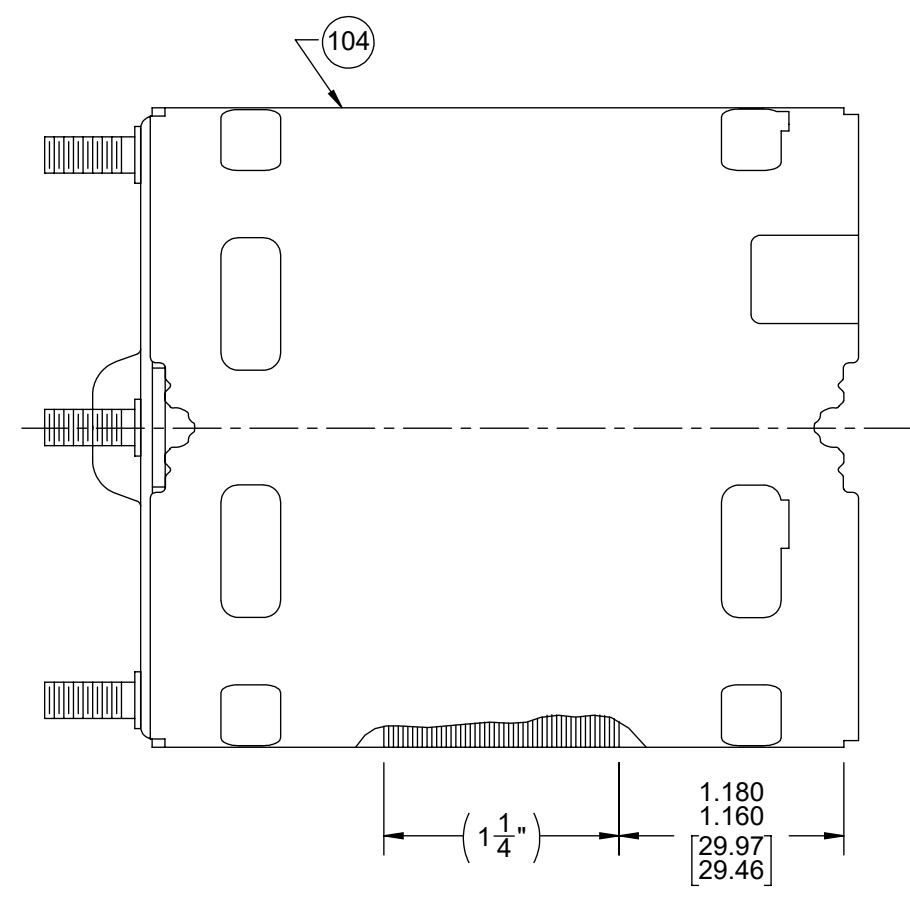

BACK END

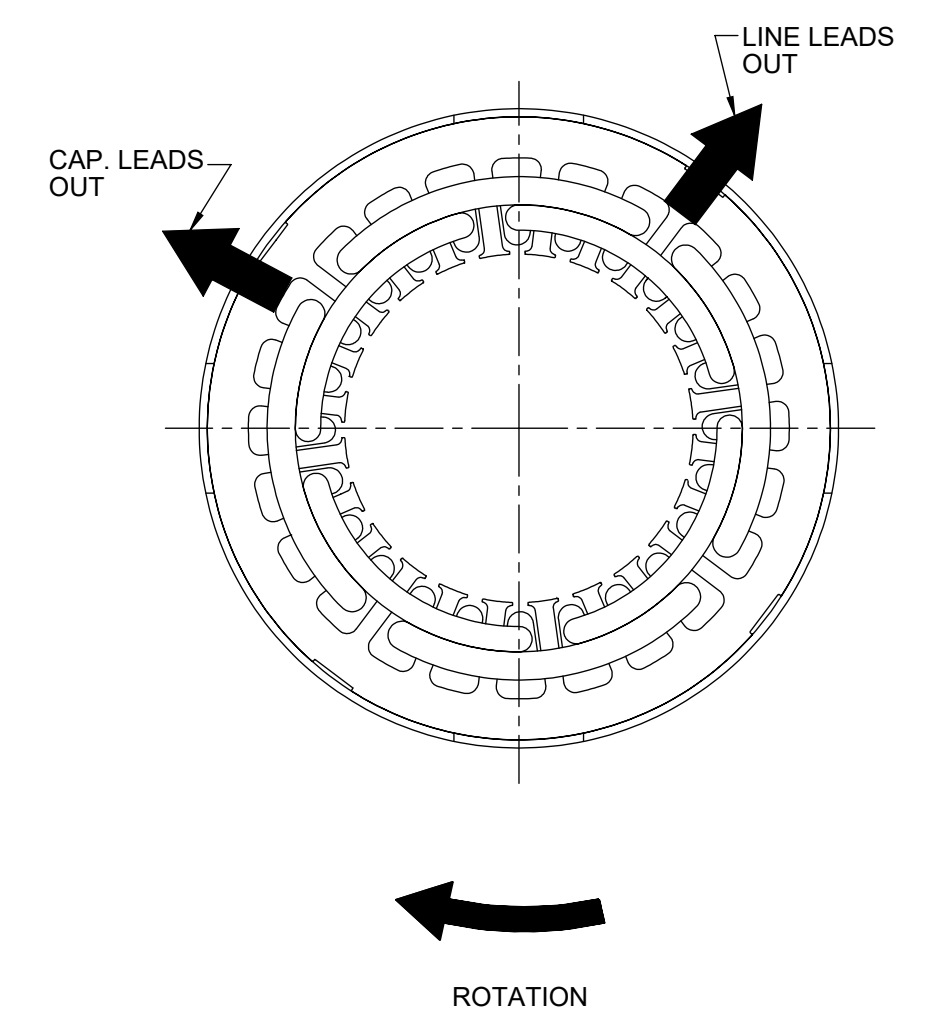

PACKING SPECIFICATIONS

- 1. PACK PER 88834200. 1 PER CARTON, 25 PER LAYER, 6 LAYERS PER PALLET, 150 MAX. AMOUNT PER PALLET.
- 2. PLACE FOAM RING ON BACK END OF MOTOR, PLACE FILLER TUBE OVER SHAFT EXTENSION AND PLACE MOTOR IN CARTON, STUFF PAPER AROUND MOTOR TO PREVENT MOVEMENT DURING SHIPMENT.
- 3. PLACE (1) FLAT PAD ON PALLET, (1) BETWEEN EACH LAYER AND (1) ON TOP.
- 4. CARTON LABELS MUST ALL FACE ONE DIRECTION TOWARD OPEN END OF PALLET.

|                                                                                                                                                                                                                                                                                                                                                                                                                                                                                                                                                                                                                                                                                                     |                    |                               |                                                                                          |                    |                                   |
|-----------------------------------------------------------------------------------------------------------------------------------------------------------------------------------------------------------------------------------------------------------------------------------------------------------------------------------------------------------------------------------------------------------------------------------------------------------------------------------------------------------------------------------------------------------------------------------------------------------------------------------------------------------------------------------------------------|--------------------|-------------------------------|------------------------------------------------------------------------------------------|--------------------|-----------------------------------|
| DRAWING REVISION<br>GB                                                                                                                                                                                                                                                                                                                                                                                                                                                                                                                                                                                                                                                                              | REVISION BY<br>SDM | REV DATE/@ DATE<br>10/12/2022 | TOLERANCES (EXCEPT AS NOTED):<br>DEC. INCH mm ANGLE                                      | DRAWN BY<br>RPT    | Regal Beloit America, Inc.        |
| REQUEST NUMBER<br>ECR-0221356                                                                                                                                                                                                                                                                                                                                                                                                                                                                                                                                                                                                                                                                       | APPROVED BY<br>MLS | DATE<br>10/12/2022            | .X ±0.1 [±3] ±1°<br>.XX ±0.01 [±0.3]<br>.XXX ±0.005 [±0.13]<br>.XXXX ±0.0005 [±0.013]    | DATE<br>11/05/2015 |                                   |
| REQUEST NUMBER DESCRIPTION<br>CHANGE NAMEPLATE FASCO LOGO TO FASCO TM                                                                                                                                                                                                                                                                                                                                                                                                                                                                                                                                                                                                                               |                    |                               | REMOVE BURRS & BREAK SHARP EDGES: .003/.015 [.08/.38] X 45°<br>CORNER FILLETS: R.02 [.5] | APPROVED BY<br>JMG | DESCRIPTION<br>OUTLINE MOTOR ASSY |
| <small>COPYRIGHT (PER REVISION DATE) REGAL BELOIT AMERICA, INC. ALL RIGHTS RESERVED. PROPRIETARY AND CONFIDENTIAL INFORMATION - THIS DOCUMENT IS THE PROPERTY OF REGAL BELOIT AMERICA, INC. ("OWNER") AND CONTAINS OWNER'S PROPRIETARY INFORMATION. ANY PERSON, CORPORATION OR OTHER FIRM RECEIVING IT IS DEEMED, BY RECEIVING IT, TO AGREE THAT IT, AND/OR ANY PART OF IT, SHALL NOT BE DISCLOSED TO ANY PERSON, CORPORATION OR OTHER ENTITY, DUPLICATED, AND/OR USED, EXCEPT AS EXPRESSLY APPROVED IN WRITING IN ADVANCE BY OWNER. THIS DOCUMENT SHALL BE RETURNED TO OWNER UPON REQUEST. IT MAY BE SUBJECT TO CERTAIN RESTRICTIONS UNDER APPLICABLE EXPORT CONTROL LAWS AND REGULATIONS.</small> |                    |                               | MACHINED SURFACES: .125/ mm 3.2 INCH/mm                                                  | DATE<br>11/05/2015 | MATERIAL                          |
|                                                                                                                                                                                                                                                                                                                                                                                                                                                                                                                                                                                                                                                                                                     |                    |                               | mm DIMENSIONS IN [BRACKETS] ARE FOR REFERENCE ONLY                                       | REFERENCE          | PROCESS/FINISH<br>BLACK           |
|                                                                                                                                                                                                                                                                                                                                                                                                                                                                                                                                                                                                                                                                                                     |                    |                               | THIRD ANGLE PROJECTION                                                                   | SIZE<br>C          | DRAWING NUMBER<br>71903004        |
|                                                                                                                                                                                                                                                                                                                                                                                                                                                                                                                                                                                                                                                                                                     |                    |                               |                                                                                          |                    | SHEET<br>2 OF 2                   |