

MODEL NUMBER
ZR108KCE-TFD-411
ZR125KCE-TFD-411
ZR144KCE-TFD-411
ZP137KPE-TFD-411

SPECIFICATIONS	
ES NO.	DESCRIPTION
ES92-155	CONVERSION-METRIC

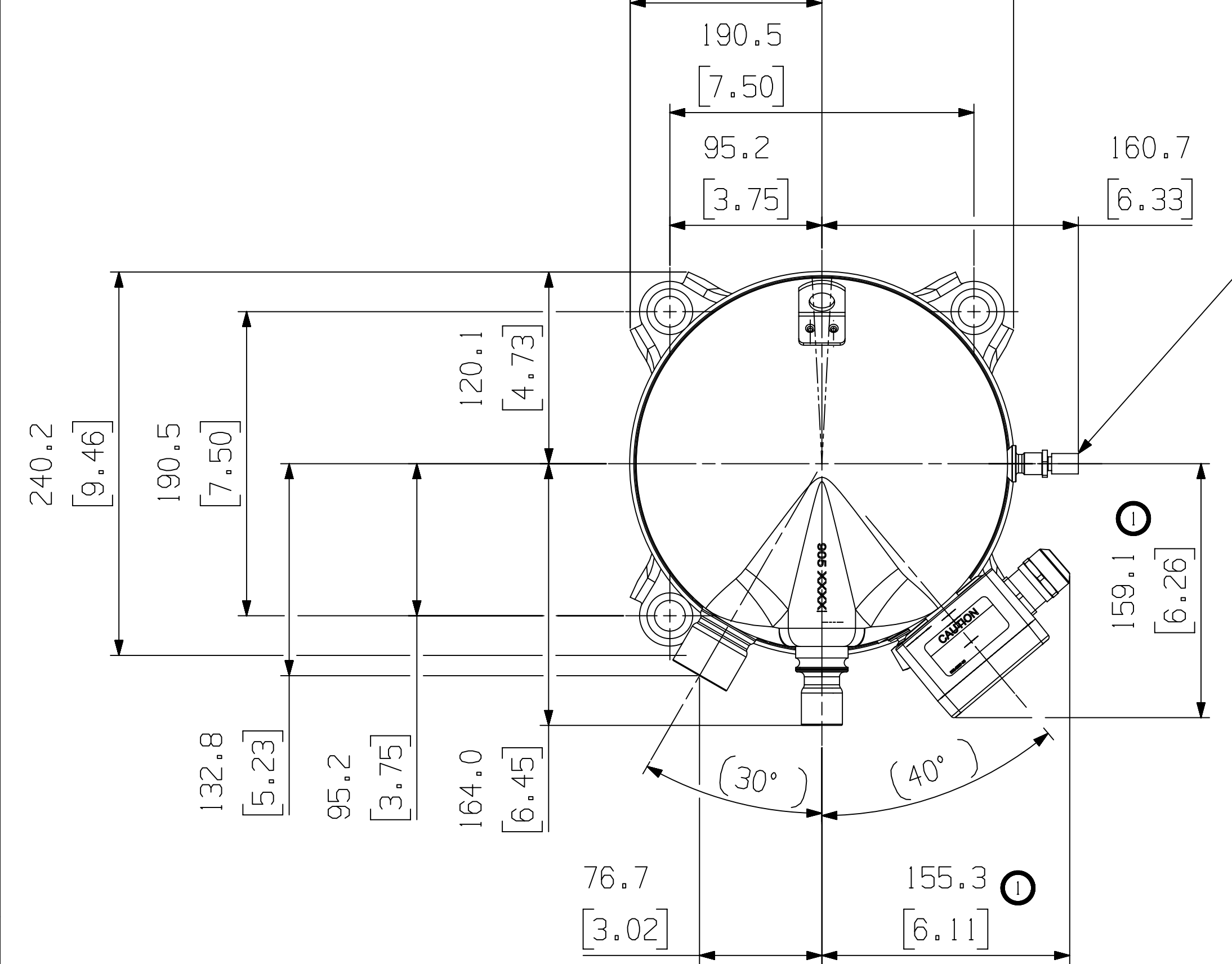

◈ $\varnothing 9.60-9.78$ [0.378-0.385] ID
 $\nabla 9.4$ [0.370] MIN.
 M9 x 1.25-6H THRU, THREADS TO BE
 FREE OF COPPER PLATING.
 0.06 [0.002] MIN. THICK EXTERIOR AND
 0.038 [0.0015] MIN. THICK INTERIOR
 COPPER PLATED STEEL OIL LEVEL FITTING

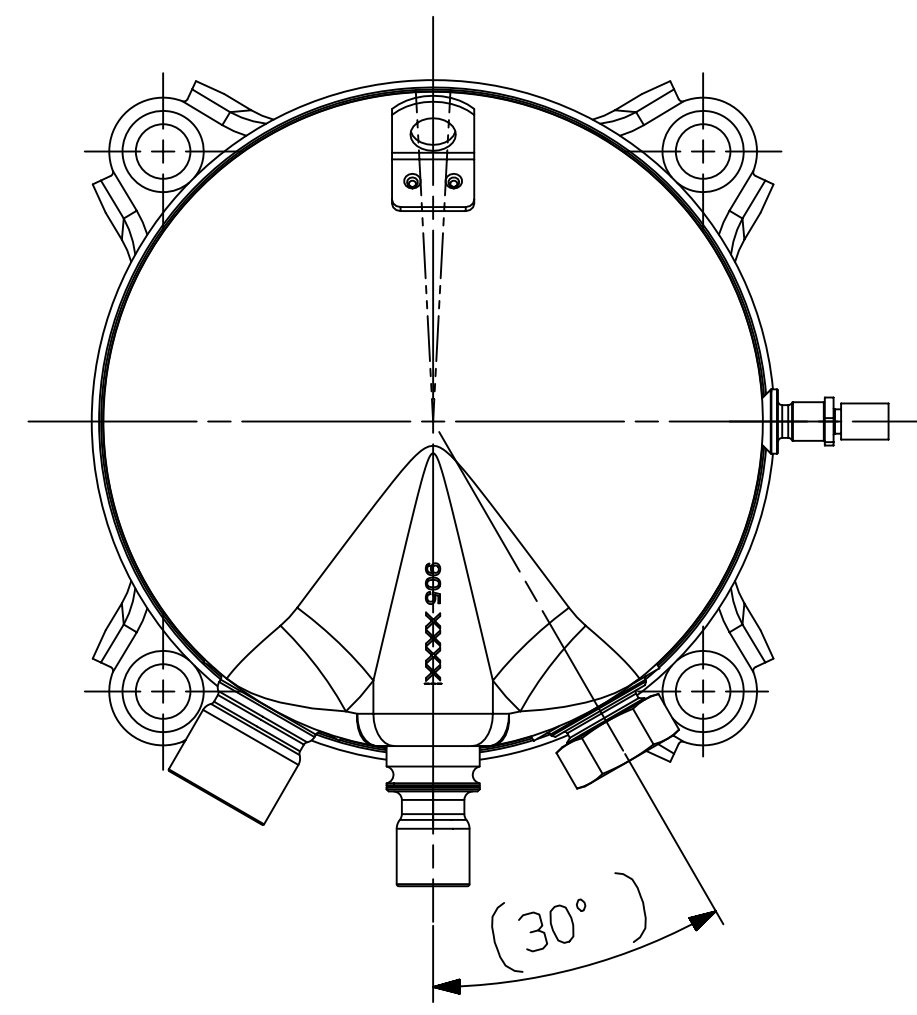

SIGHT GLASS LAYOUT
T-BOX REMOVED

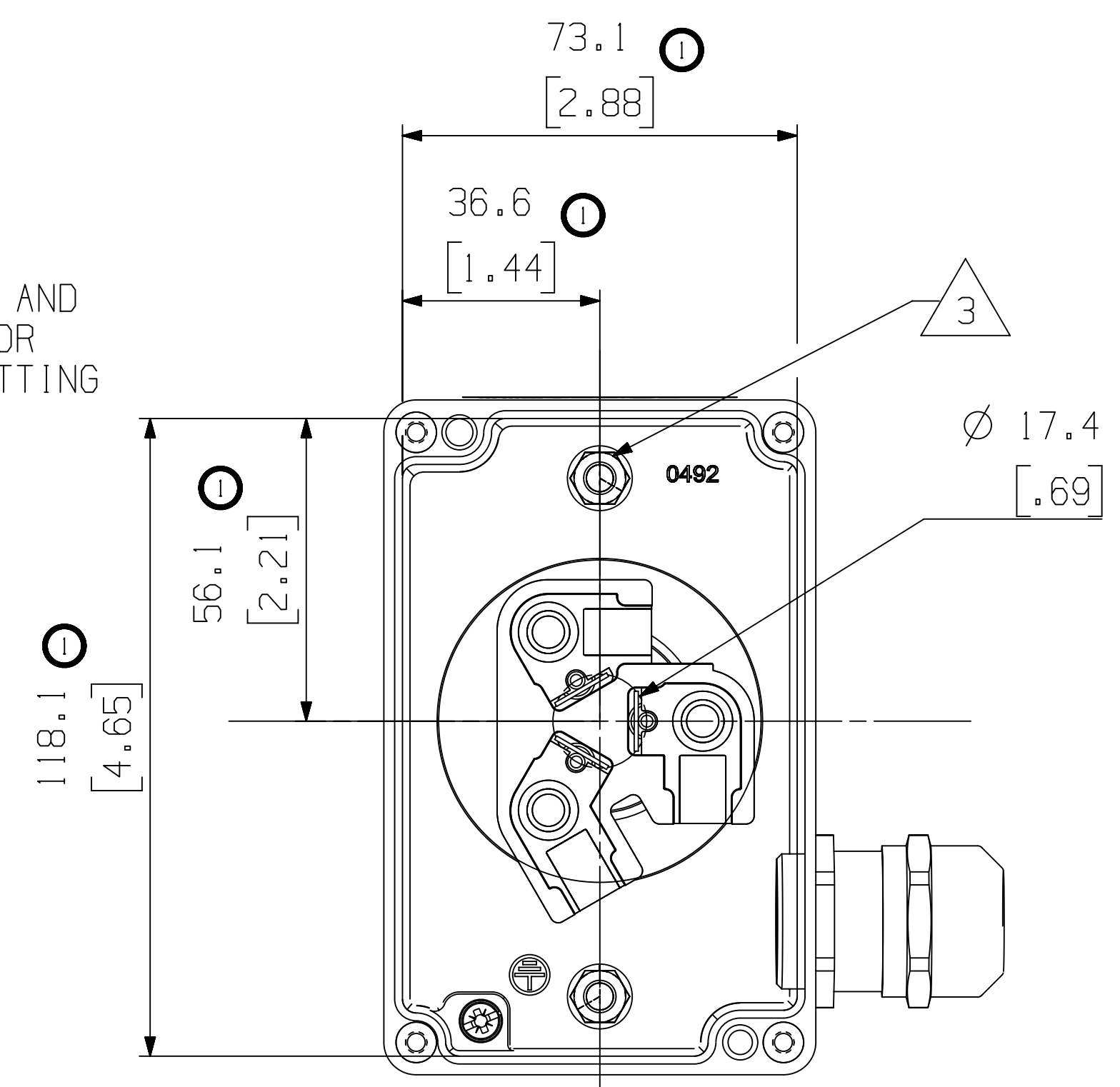

T-BOX LAYOUT STANDARD
T-BOX COVER REMOVED
SCALE 1:1

- NOTES:
- 1 ALL TOLERANCES ± 1.5 [0.06] UNLESS OTHERWISE SPECIFIED. DUE TO ACCUMULATED ASSEMBLY TOLERANCES THE LISTED COMPONENTS MAY VARY FROM THE MOUNTING HOLES AS TABULATED.
 - ◈ SUCTION FITTING ± 3.0 [0.12]
 - ◈ DISCHARGE FITTING ± 3.0 [0.12]
 - 2. TUBE ENDS MUST BE PLUGGED.
 - 3 GROUNDING SCREW AND WASHER PER BOM.

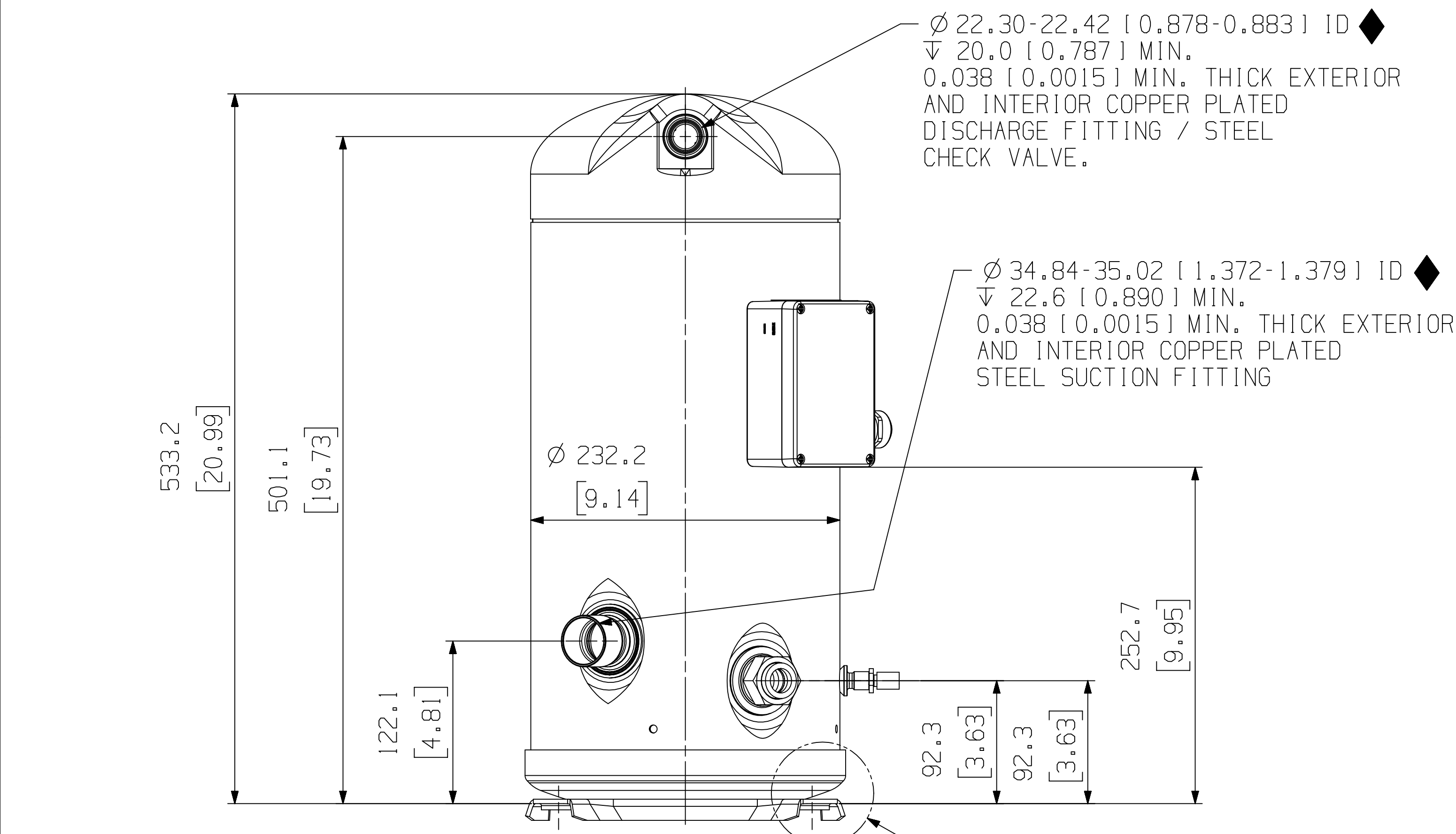

◈ $\varnothing 22.30-22.42$ [0.878-0.883] ID
 $\nabla 20.0$ [0.787] MIN.
 0.038 [0.0015] MIN. THICK EXTERIOR
 AND INTERIOR COPPER PLATED
 DISCHARGE FITTING / STEEL
 CHECK VALVE.

◈ $\varnothing 34.84-35.02$ [1.372-1.379] ID
 $\nabla 22.6$ [0.890] MIN.
 0.038 [0.0015] MIN. THICK EXTERIOR
 AND INTERIOR COPPER PLATED
 STEEL SUCTION FITTING

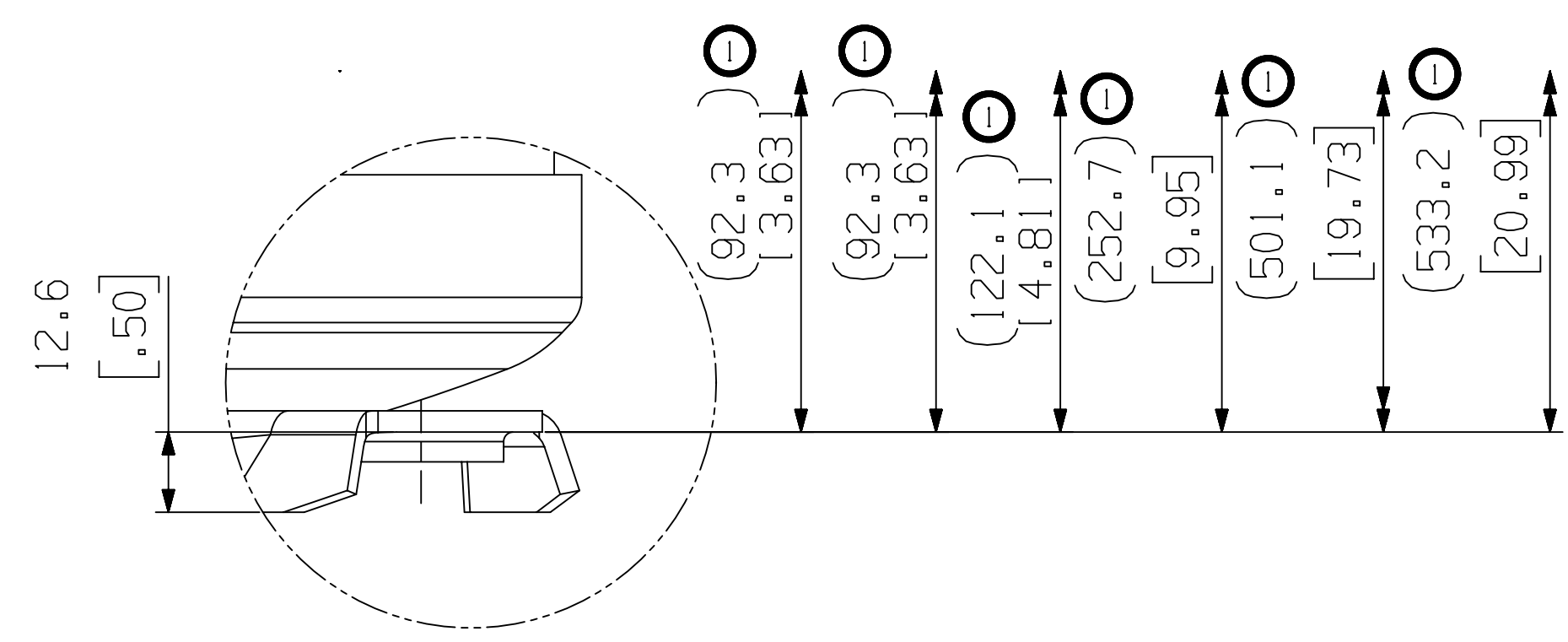

DETAIL Y
SCALE 1:1

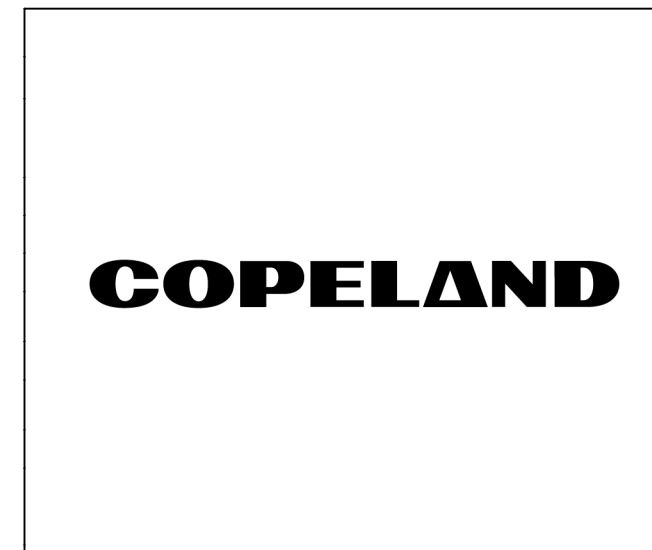
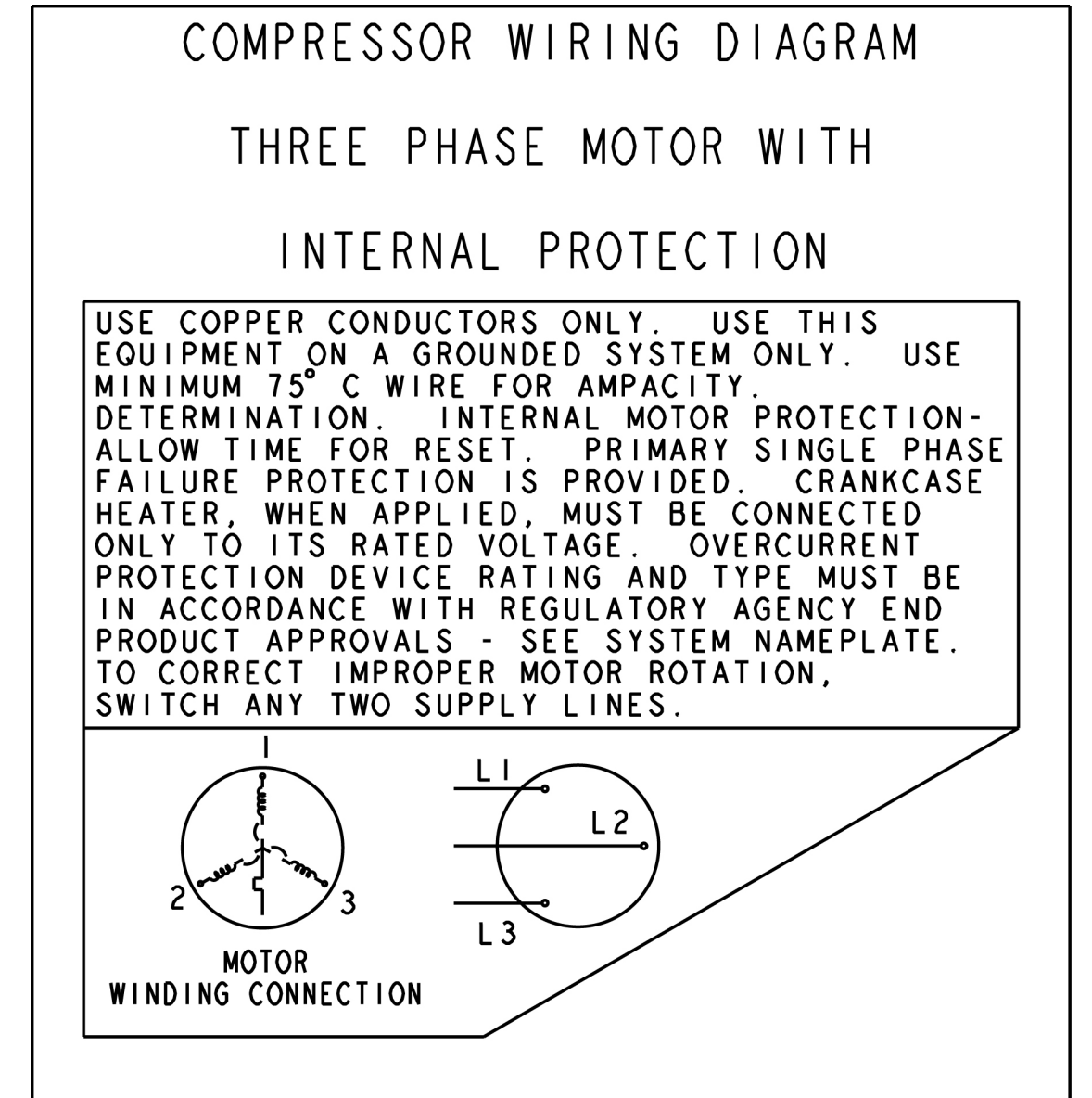

INTERPRET PER ASME
 Y14.5M-1994 AND
 COPELAND DESIGN
 STANDARDS DS2002
 DO NOT SCALE DRAWING
 CRITICAL PRODUCT CHARACTERISTICS
 UNLESS OTHERWISE SPECIFIED
 DIMENSIONS ARE MILLIMETER OR (INCH)
 TOLERANCES:
 1-PLACE : N/A
 2-PLACE : N/A
 ANGULAR : N/A

ECN325210	3	UPDATED TITLE BLOCK	08-30-23		
ECN308819	2	ADDED AFFECTED MODELS	10-16-18	IRK	VC
ECN300208	1	CHANGED T-BOX	12-28-17	KVB	KB
ECN200156	0	RELEASED	03-31-16	MNT	MD
ENG NOTICE NO.	REV.NO.	REVISIONS	DATE	BY	CHKD
15		CONFIDENTIALITY NOTICE			
THIS DRAWING AND INFORMATION CONTAINED HEREIN ARE THE EXCLUSIVE PROPERTY OF COPELAND LP AND/OR ITS AFFILIATES (COLLECTIVELY "COPELAND") AND SHALL BE RETURNED UPON DEMAND AND SHALL NOT BE REPRODUCED IN WHOLE OR IN PART, DISCLOSED TO ANYONE ELSE OR USED, WITHOUT THE WRITTEN CONSENT OF COPELAND.					
MATERIAL SPECIFICATION		DATE	SUPERSEDES DWG NO /	REV NO	
N/A		03-31-16	3:8	- / -	
TITLE			DRAWING NUMBER	SHEET 1 OF 1 DWG	
REF DWG-WELD COMP ASSM			497-1931-01	4	
SIZE					